



# ***USER'S MANUAL***

# ***RS1***



## Dear tinbot user

Welcome to join the family of tinbot motorcycle owners! We will guide you to use each function of RS1 electric motorcycle correctly and safely. In order to ensure your driving safety, please read this manual carefully before riding.

Please enter your vehicle's serial number in the form below

VIN Nr.:	seller seal
Motor number:	

The instruction manual conforms to the latest version of this series of products at the time of printing. However, slight deviations due to redevelopment of the motorcycle design cannot be completely ruled out.

All statements contained in this document are non-binding. tinbot reserves the right to modify or completely delete technical descriptions, drawings, materials, service and maintenance, design, configuration and similar content without prior notice or reason; reserves the right to adjust the above content according to local conditions , and the right to discontinue production of specific models without prior notice. tinbot is not liable for deviations from the delivery method, illustrations and descriptions, as well as typographical errors and defects. The vehicle models shown in the illustrations partially include special equipment that is not included in the standard configuration.

If you have any questions about this motorcycle, please contact tinbot customer service center, and we will provide you with advice and support at any time.

Wishing you a safe and enjoyable riding experience!

## Table of contents

Dear tinbot user .....	2
1 Format specification .....	6
1.1 Symbols .....	6
1.2 Formats .....	6
2 Safe Use Guidelines .....	6
2.1 Scope of use .....	6
2.2 Safety Tips .....	7
2.3 Danger levels and symbols .....	7
2.4 Safe operation .....	7
2.5 Protective suit .....	8
2.6 Operating regulations .....	8
2.7 Environment .....	8
2.8 User manual .....	9
3 Important Notes .....	9
3.1 Warranty, repairing .....	9
3.2 Auxiliary materials .....	9
3.3 Spare parts, accessories .....	10
3.4 Maintenance .....	10
3.5 Drawing .....	10
3.6 Customer service .....	10
4 Vehicle View .....	11
4.1 Vehicle view - Left View (Schematic Diagram) .....	11
4.2 Vehicle view - top view (schematic diagram) .....	11
5 serial number .....	12
5.1 VIN .....	12
5.2 Nameplate .....	12
5.3 Motor number .....	13
6 Control Unit .....	13
6.1 Front brake handle .....	13
6.2 Rear brake handle .....	13
6.3 Switch handle .....	14
6.4 Ignition/steering lock .....	14
6.5 Remote control .....	15
6.6 Start switch .....	15
6.7 Driving mode switch .....	16
6.8 Double flash switch .....	16
6.9 Dimmer switch .....	16
6.10 Turn signal switch .....	17
6.11 Horn button .....	17

6.12 Seat lock .....	17
6.13 Charging dock .....	18
6.14 Side stand .....	18
7 Instrument display .....	19
7.1 Speed display .....	19
7.2 Riding mode display .....	19
7.3 Current indication .....	19
7.4 Mileage display .....	20
7.5 Temperature display .....	20
7.6 Battery Display .....	21
7.7 Charging indication .....	21
7.8 Turn indicator .....	22
7.9 READY indicator .....	22
7.10 Other indicators .....	22
7.11 Error code display .....	23
7.12 Screen setting mode .....	24
8 How to drive RS1 .....	24
8.1 Inspection and maintenance before each ride .....	24
8.2 Switch on .....	25
8.3 Start .....	26
8.4 Braking .....	26
8.5 Stop, Parking .....	27
8.6 Switch off .....	27
8.7 Transport vehicles .....	28
8.8 Transport the battery .....	28
9 Maintenance plan .....	28
9.1 Necessary inspection work .....	28
9.2 Recommended inspection tasks .....	29
10 Vehicle Adjustment .....	30
10.1 Adjustment of the rebound damping of the front shock absorber .....	30
10.2 Checking the chain tightness .....	30
10.3 Adjusting the chain tightness .....	31
10.4 Checking the chain cleanness .....	32
10.5 Cleaning the chain .....	32
11 brake system .....	32
11.1 Checking the brake disc .....	32
11.2 Check brake pads .....	33
11.3 Checking the brake fluid .....	33
12 Wheels, tires .....	34
12.1 Check the status of wheels and tires .....	34

12.2 Check tire pressure .....	35
13 battery .....	35
13.1 Connecting the battery communication cable .....	35
13.2 Charging the battery .....	36
14 Motor maintenance work .....	38
14.1 Checking the motor gear oil level .....	38
14.2 Replacing the motor gear oil .....	39
15 Cleaning, Maintenance .....	40
15.1 Cleaning the motorcycle .....	40
15.2 Inspection and maintenance work during winter use .....	40
16 storage .....	41
16.1 Storage .....	41
16.2 Preparation before use after storage .....	42
17 Error code table .....	42
18 Technical parameters .....	43
18.1 Motors .....	43
18.2 Vehicle .....	44
18.3 Electrical system .....	45

# 1 Format description

## 1.1 Symbols

The symbols used are explained below.



All tasks marked with this symbol require specialized knowledge and technical background.

For your own safety, please go to an authorized tinbot after-sales service center to perform these tasks! Here, your motorcycle will be optimally maintained by specially trained professionals using the required special tools.



Indicates the referenced page (further information is contained in a given page).



Indicates that a note contains additional information or tips.

---

## 1.2 Format used

The text format used is explained below.

**proper noun**                      Indicates proper noun

Terms marked by                      Refer to technical details of the vehicle or to mark technical terms that will  
underlining                              be explained in the glossary.

---

# 2 Safety Recommendations

## 2.1 Scope of use

tinbot electric sport motorcycles are designed and constructed to withstand the normal loads of regular use. Symbols and marks of this motorcycle conform to the relevant regulations and standards of the European Union.



### **information**

Only trained personnel are allowed to use the vehicle.

---

## 2.2 Safety Tips

In order to use the vehicle safely, the safety instructions must be observed. Therefore, please read this manual carefully. Safety tips are highlighted in text and linked to the relevant location.



### information

There are different reminder labels/warning labels at visible locations on the vehicle. Please do not remove any reminder labels/warning labels. If these labels are missing, you or others may not be able to identify the possible dangers, which could result in injury.

---

## 2.3 Danger levels and symbols



### Danger

Indicates a direct fatal danger or serious injury if the corresponding precautions are not taken.



### Warning

Risk of possible death or serious injury if the corresponding precautions are not taken.



### Caution

Risk of minor injury if the corresponding precautions are not taken.



### Notice

Indicates a risk of severe damage to the machine or components if the corresponding precautions are not taken.



### Alert

Indicates possible environmental hazards if appropriate precautions are not taken.

---

## 2.4 Safe operation

Only use the vehicle in a state free of any technical defects, driver must be safety-conscious and environmentally-conscious during the riding!

When used in road traffic, driver's license is required.

Faults that affect safety should be rectified immediately at an authorized tinbot after-sales service center.

Observe the warning labels/caution labels placed on the vehicle.

**Danger**

Impaired driver's judgment may result in fatal danger.

Do not drive this vehicle after drinking alcohol, taking medicines and drugs, or even when you are not physically or mentally ready.

**warn**

Some parts of your vehicle very hot in running.

Do not touch parts with high temperature, such as motor, shock absorber, brake system. Allow parts to cool before working on them.

---

## 2.5 Protective suit

For your own safety, tinbot recommends only riding the vehicle while wearing appropriate protective suit.

**warn**

Not wearing protective suit or wearing defective protective suit increases safety risks.

- Protective suit (helmet, boots, gloves, protective trousers and jacket) is required in all driving situations.
  - Always wear flawless, legally compliant protective suit.
- 

## 2.6 Operating Regulations

In some circumstances, special tools are required. Please contact KOLLTER's authorized service provider for help.

During assembly, parts that cannot be reused (such as self-locking bolts and nuts, seals, O-rings, cotter pins, washers) must be replaced with new ones.

For some bolts, a thread compound (eg Loctite®) is required. The manufacturer's specific instructions must be observed during use.

Parts to be reused after disassembly shall be cleaned and inspected for damage or wear, and damaged or worn parts shall be replaced.

After repairs or maintenance have been completed, the safe operation of the vehicle must be ensured.

## 2.7 Environment

Treating your motorcycle with care can avoid unnecessary problems. In order to ensure that motorcycles can still be used in future, please ensure that you use motorcycles within the scope of the law, please be environmentally conscious, and respect the rights of others.



Observe the relevant state laws and guidelines when disposing of used oil, other fuel and auxiliary materials, as well as used parts.

Your authorized tinbot dealer is here to help you at any time.

## 2.8 User Manual

Before driving for the first time, please read this instruction manual carefully and completely. The owner's manual contains a wealth of information and tips to help simplify the operation, use and maintenance of the vehicle. Only then will you know how to adjust the vehicle to your situation and how to protect yourself from injury.

Keep the instruction manual within easy reach so you can refer to it whenever you need it.

If you would like more information about your vehicle, or if you have unclear questions while reading, please contact an authorized tinbot dealer.

The instruction manual is an important part of the vehicle and must be passed on to the new owner after selling.

## 3 Important Notes

### 3.1 Warranty, repair

The operations stipulated in the maintenance plan are only allowed to be carried out in tinbot authorized after-sales service centers, and confirmed in the maintenance and warranty manual, otherwise, any right to apply for warranty and repair will be lost. The warranty is void in the case of damage and subsequent damage caused by incorrect handling and/or modifications to the vehicle.

Please refer to the Warranty Manual for details on the Warranty or repairing.

### 3.2 Auxiliary materials



#### **Alert**

**Environmental Hazard** Improper disposal of lubricants can be hazardous to the environment.

Lubricating oil must not be poured into ground water, soil or piping systems.

---

- ) Only use the auxiliary materials described in the instruction manual

### **3.3 Spare parts, accessories**

For your own safety, use only spare parts and accessory products approved and/or recommended by tinbot and have them installed at an authorized tinbot after-sales service center. tinbot is not responsible for the use of other products and the resulting losses .

Authorized spare parts and accessory products are enclosed in appendix. Your authorized tinbot dealer will be happy to advise you.

About the latest vehicle tinbot parts and accessories , visit the tinbot website.

tinbot International Website: <http://www.tinbot-tech.com>

### **3.4 Maintenance**

A prerequisite for trouble-free operation and avoiding premature wear is to observe the care, maintenance and adjustment work on the motor and chassis specified in the user manual. Incorrect chassis tuning can lead to damage and breakage of chassis components.

Using the vehicle in harsh conditions such as sandy, slippery or muddy roads/areas may cause increased wear on the transmission system, braking system or shock absorbing components, etc. Parts may therefore need to be inspected or replaced before the next service interval is reached.

Follow the specified running-in period and maintenance intervals. Strict adherence to this regulation can significantly increase the service life of the motorcycle.

### **3.5 Drawings**

The drawings shown in this manual include some optional equipment.

### **3.6 Customer Service**

tinbot Dealers are here to answer your questions about your vehicle and tinbot . the

tinbot website for a list of authorized tinbot dealers .

tinbot International Website: <http://www.tinbot-tech.com>

## 4 Vehicle view

### 4.1 Vehicle View - Left View (Schematic Diagram)

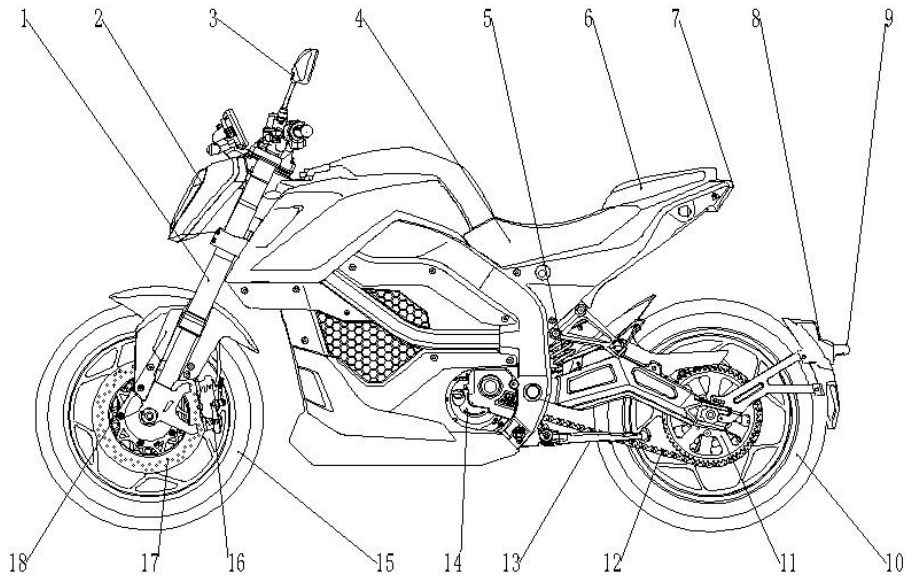

- ① Front shock absorber ② Headlight ③ Rear view mirror ④ Front seat cushion ⑤ Rear shock absorber ⑥ Rear seat cushion ⑦ Rear tail light  
⑧ Rear Reflector ⑨ License Plate Light ⑩ Rear Tire ⑪ Rear Sprocket ⑫ Chain ⑬ side stand ⑭ Motor  
⑮ Front tire ⑯ Front disc brake pump ⑰ Front brake disc ⑱ Side reflector

### 4.2 Vehicle View - Top View (Schematic Diagram)

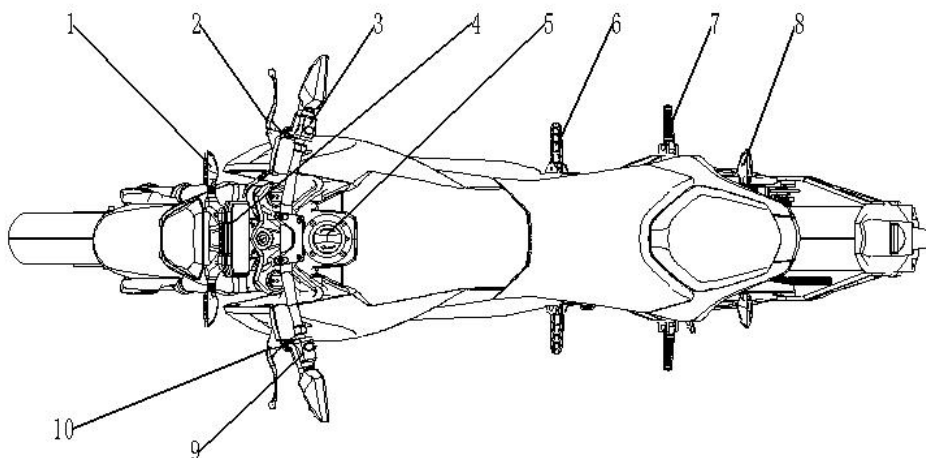

- ①Front turn signal ②Front brake handle ③Right handle switch ④Speedometer ⑤Charging port  
⑥Front footrest ⑦Rear footrest ⑧Rear turn signal ⑨Left hand handle switch ⑩Rear brake handle

## 5 serial number

### 5.1 VIN

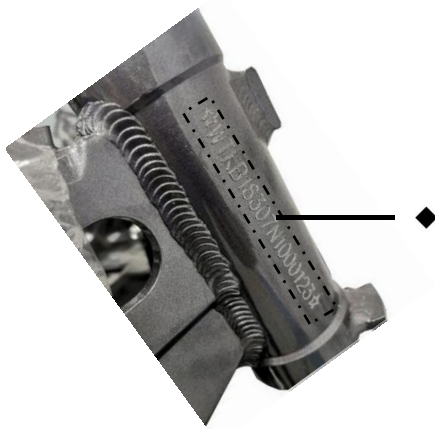

VIN◆ Engraved on the right side of the steering head tube.

### 5.2 Nameplate

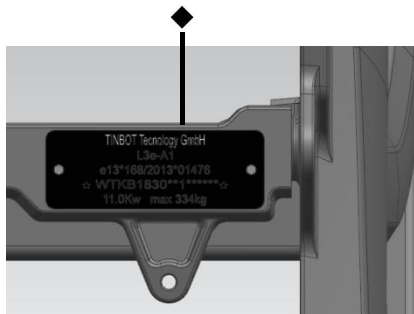

nameplate◆ Installed at the rear of the vehicle, on the frame to the right of the rear shock.

## 5.3 Motor number

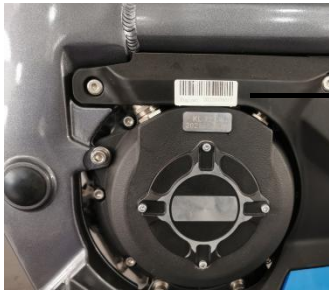

The motor number is printed on the upper part of the right cover of the motor.

On the right decorative cover of the motor, there is a barcode label of the motor number ◆ for easy viewing.

## 6 control elements

### 6.1 Front Brake Lever



front brake lever ◆ Installed on the right side of the steering bar.

### 6.2 Rear brake handle



rear brake handle ◆ Installed on the left side of the steering bar.

## 6.3 Switch handle



switch handle◆ Located on the right side of the steering bar.

## 6.4 Ignition/steering lock

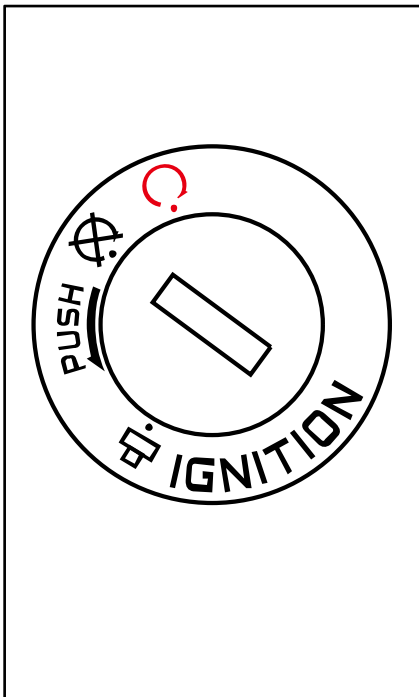

The ignition/steering lock is between the steering bar and the instrument panel,

- Turn the key to this position, the vehicle starts.
- ⊗ Turn key to this position, the vehicle is off
- ⊞ Turn the key to this position, the steering system is locked.

### **i** information

The steering lock is used to lock the turning of the steering bar, so you can no longer ride. Use the front locks when parking to prevent illegal use or theft of the vehicle.

### lock the steering system

1. Turn the steering bar to the leftmost position.
2. key is inserted into ⊗ position, press the key, release it, and turn it counterclockwise to the ⊞.
3. Pull out the key.

### unlock the steering system

1. Insert the key into the ignition/steering lock. Turn clockwise to ⊗ position.

- pull out the key

## 6.5 Remote control

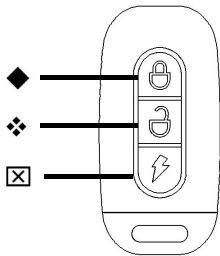

We have adopted an advanced smart remote control, you can easily lock or unlock RS1 just by pressing the button within 50 meters. The functions are as following:

- ◆ 🔓 Unlock button: press this button, the vehicle is unlocked, and the start button flashes.
- ❖ 🔒 Lock button: When the vehicle is parking, press this button to lock the vehicle.
- ☒ ⚡ Remote start key: Press this key twice quickly to start the vehicle.

## 6.6 Start switch



- ◆ When ☒ is pressed down, the vehicle is in the P gear state, the 'P' indicator lighting on the instrument panel, and the vehicle cannot be ridden.  
When ○ is pressed down, and the side stand is lifted up, the vehicle will release the P gear, the READY indicator on the instrument will light up, and the vehicle can be ridden.



### information

**For your own safety, every time when you start vehicle, even if it' ○ in position, and the vehicle cannot be directly ridden, the start switch must be pressed back to ☒ , and then dial it back ○ again, then you can ride.**

## 6.7 Driving mode switch



drive mode switch ◆ is located on the right hand of handlebar.

It can be switched among the three gears of ECO gear, D gear and S gear.

ECO is Economical gear,

D is the standard gear,

S is the sports gear.

## 6.8 Double flash switch



Press the double flash switch ◆ The turn signals on both sides flash at the same time to remind other drivers to pay attention to the situation, including the need to stop in an emergency.

Press the button again to turn off the warning signal.

## 6.9 Dimmer switch

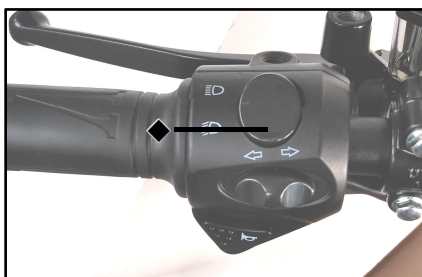

dimmer switch ◆ Located on the left handlebar.

When the upper part of the switch is pressed, the headlights are switched from low beam to high beam. And keep it in this position until the lower part of the switch is pressed to switch to low beam. When the high beam is on, the high beam indicator on the instrument panel will also be lighted up simultaneously.



## 6.10 Turn signal switch



turn signal switch ◆ is located on the left handlebar.

When the turn signal is shifted to the left or right, the corresponding front and rear turn signals will flash. When the turn signal is on, the corresponding turn signal indicator on the instrument panel will also be illuminated.

Please operate your signal lights as required by law. Unlike a motorcycle, on a motorcycle the turn signal must be canceled manually. To cancel, push the switch to the middle position.

## 6.11 Horn button

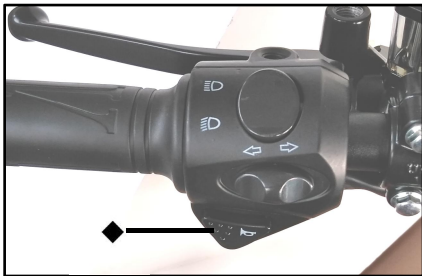

When the key is in the ON position, press this button and the ◆ horn will sound. The horn can be used to alert pedestrians or other riders to their attention.

## 6.12 Seat lock



The seat cushion lock ◆ is located on the rear left side of the vehicle body.

### open seat cushion

Insert the key and turn it clockwise. When you hear a "click", grab the back of the seat cushion and lift it up to open the seat cushion.

## 6.13 Charging Dock



This model provides two charging options, one is located in front of the seat cushion, ◆ and can be opened for charging after rotating the charging cover.



The other charging port is located under the front of the rear guard plate, and the charging port can be opened after the charging cover is lifted up.

## 6.14 Side stand

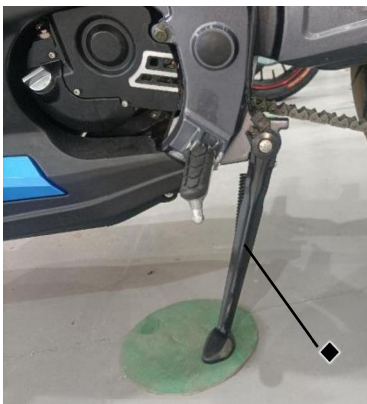

The side stand is mounted on the left side of the vehicle



### information

When you ride, kick up the side stand first.

## 7 Instrument panel

### 7.1 Vehicle speed display



Show real time speed

### 7.2 Riding mode display

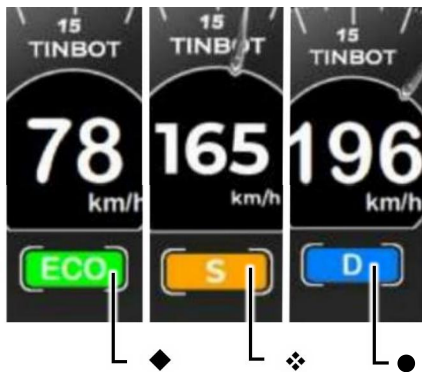

The riding mode is a toggle switch, which is located on the right hand handlebar.

1. ECO ◆ Economic mode
2. S ❖ Sports mode
3. D ● Standard mode

### 7.3 Current indication



current indicator ◆ displays real-time current in the form of a scale bar. You can roughly judge the real-time current through the scale bar.

## 7.4 Mileage display



1. ◆ODO: total mileage driven
2. ❖TRIP: short trip mileage
3. ●RANGE: Remaining mileage

## 7.5 Temperature display



The value displayed in the temperature indicates the real time battery temperature



The value displayed indicates the current ambient temperature

## 7.6 Battery Display



The value indicates the current battery capacity

## 7.7 Charging indication



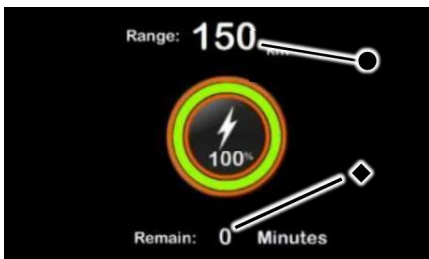

During the charging process, the speedometer displays the charging interface ◆ to display the current charging status in percentage. If there is no operation within 20 seconds, the screen will automatically turn off until the VCU detects the remote control, or receives signal to find the motorcycle or unlocking.



- Indicates the estimated mileage of the current battery capacity
- ◆ Indicates the estimated time it will take for the battery to be fully charged

## 7.8 Turn signal indicator



1. When the left turn signal is turned on, the left turn indicator  illuminates and flashes together with the turn signal.
2. When the right turn signal is turned on, the right turn indicator  illuminates and flashes together with the turn signal.





## 7.9 READY indicator



"READY"  (ready to run), this light illuminates to indicate that the vehicle is ready to be driven.

## 7.10 Other indicators



1. ABS  error indicator light
2. When the high beams  are on, the high beam indicator light glows blue until the high beams go out.
3. When the OBD  error indicator is on, it indicates that the vehicle has malfunctioned. Please check with an authorized dealer.
4. The maintenance reminder system  will automatically remind you to replace the gearbox gear oil according to the mileage and time of your trip. You can clear this reminder manually after changing the oil, or have our service personnel clear it for you.



1. stop light ●
2. Settings indicator ◆
3. mode light ▲

## 7.11 Error code display



When the motorcycle fails, the corresponding error code ◆ will be lighted up in the error code display area

(Refer to  page 40 )



### Caution!

When this signal appears, please stop and check immediately.

## 7.12 Instrument panel setting mode

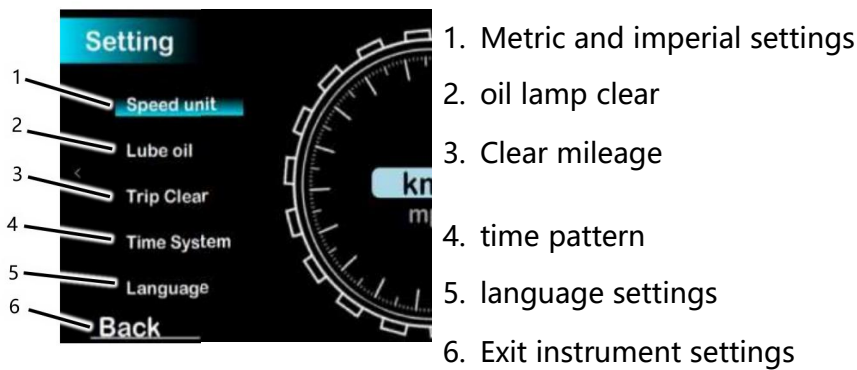

## 8 How to drive the motorcycle

### 8.1 Inspection and maintenance before each drive



#### information

Before each drive, check the condition of the vehicle to ensure safe operation.

Before riding the RS1 motorcycle, please be sure to check the following items, which will ensure your safety on the road.

- Check that the electrical system is working properly.
- Whether the battery power is sufficient.
- Whether the steering handle is stable and the rotation is flexible.
- Whether the switches on the left and right handlebars are working properly.
- Whether the speed control handle is working normally.
- Whether the amount of brake oil is sufficient, whether the handle and the brake system work normally.
- Check the front brake hose.
- Check the rear brake hose.
- Check chain cleanliness.
- Check chain tension.
- Check the chain, front and rear sprockets and chain guides.
- Make sure the tire pressure is normal, recommended tire pressure (KPa):



- Single 280/280 (front/rear wheels)
- Dual 280/280 (front/rear wheels)
- Check the tire surface for cracks, damage, wear, puncture or adhesion of foreign matter.
- Whether the tread depth is sufficient, deeper than 0.8 mm.
- Check if any error warning lights on the instrument panel after power is turned on.
- Whether the head and tail lights, brake lights, and turn signals are working properly.
- Check that the horn is working properly.
- Clean the rearview mirror and adjust it to an appropriate angle.

For any questions or doubts about operation, please contact tinbot customer service center.

## 8.2 Starting the vehicle

Two starting modes available: key start and remote control start.





### information

Before each ride, make sure all wiring is properly connected and the battery charging and discharging ports are connected with cables.

Check if the air switch is on.

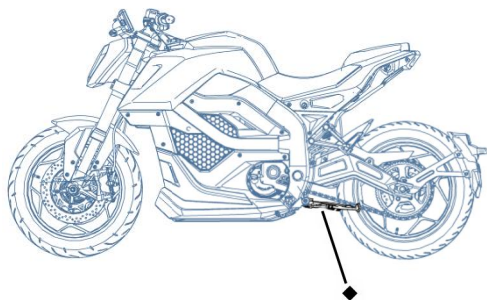
### 1) Use the key



- Kick side stand ◆ up.
- Insert the key into the ignition lock and turn it into  place.
- The vehicle emits two beeps and the vehicle starts

### 2) Use the remote control



- Click the remote unlock button ◆
- Press the remote start button twice. ●
- The vehicle emits two beeps and the vehicle starts

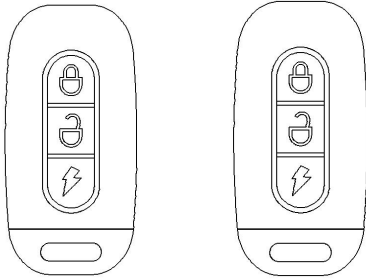

## 8.3 Ride the motorcycle



### information

The side stand must be kicked up when you are driving.

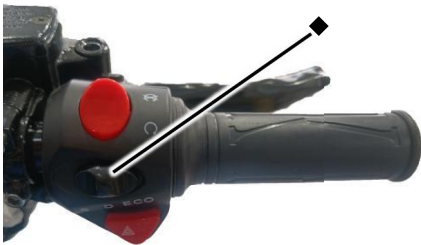

Select the drive mode select switch **◆** on the right handlebar. There are three modes to choose from.

Economy mode: ECO, power output 60%

Driving mode: D, power output 80%

Sports mode: S, power output 100%

Carefully turn throttle, the vehicle moves.

## 8.4 Braking



### warn

Braking too hard may cause the risk of wheel lockup.



### warn

If feel front and rear brake lever too soft when braking, check the braking system and do not continue driving. (Your authorized tinbot Service Center is here to help you.)



### warn

A wet or dirty brake system will reduce braking effectiveness.  
Dirty or wet brake systems should be carefully cleaned or dried.



### information

The rear brake lever is mounted on the left side of the handlebar.

- When braking, please release the throttle and operate the front and rear brakes at the same time.

- Use the rear wheel brakes as priority on sandy, wet or slippery surfaces.
- Brake early when entering bend.

## 8.5 Parking

---



### warning

**Risk of theft** and use by unauthorized persons.

Vehicles must never be parked unattended.

Prevent unauthorized persons from accessing the vehicle.



### warning

**Burn hazard** Some parts of your vehicle run very hot.

Do not touch hot parts such as motors, shock absorbers and brake systems. Allow parts to cool before working on them.



### Notice

A parked vehicle may slide or overturn.

Always park the vehicle on stable, flat ground.



### Notice

Some parts of your vehicle run very hot.

Vehicles must not be parked close to flammable and/or combustible materials. Do not place objects on parts that has reached operating temperature. The vehicle must be allowed to cool down first.



### Notice

The side stand are only designed to support the weight of the motorcycle. Do not sit on the motorcycle when it is parked on the side stand. Failure to do so may damage the side stand or frame, and the motorcycle may tip over.



---

Brake the motorcycle to a stop.

Turn off the vehicle. (see  page 26)

Park the motorcycle on firm ground.

## 8.6 Switch Off the vehicle

- 1) Shutdown with key
  - turn the key to  position, vehicle off.
  - Lock the motorcycle. (see  page 14 )
- 3) Shut down with the remote
  - Press the lock button once  til the vehicle is shutdown.

## 8.7 Transport vehicles

- Turn off the vehicle. (see previous section)
- Use fastening straps or other suitable securing devices to secure the motorcycle to prevent tipping and moving.



### **warning**

**Burn danger** Some parts of your vehicle run very hot.

Do not touch hot parts such as motors, shock absorbers and brake systems. Allow parts to cool before operating on them.



### **Notice**

A parked vehicle may slide or overturn.

Always park the vehicle on stable, flat ground.

---

## 8.8 Transporting the battery

Use fastening straps or other suitable securing devices to secure the battery pack to prevent tipping and moving.



### **warn**

The battery pack is a very important component.

- Proper protective measures must be taken during transportation, otherwise serious damage may result.
  - There is a risk of damage to the transportation of vehicle if proper protection is not provided.
- 

## 9 maintenance plan

Regular maintenance and maintenance can extend the service life and driving safety of RS1 motorcycle. It is recommended that you refer to the following suggestions to maintain your motorcycle.

### 9.1 Necessary inspection work

1500 kilometers or two months (whichever comes first) after the new motorcycle is delivered, the initial inspection and maintenance must be carried out at the tinbot service center.

Regular inspection and maintenance at tinbot Service Center is recommended every 3,000 km or every six months (whichever comes first).

Every driving 3000km (1864mi)
1500km (932mi) for the first time

	Every driving 3000km (1864mi)	
	1500km (932mi) for the first time	
Check that the electrical system is working properly.	○	●
Check the battery pack	○	●
Whether the steering handle is stable and the rotation is smooth		●
Whether the switches on the left and right handlebars are working properly.		●
Whether the amount of brake oil is sufficient, whether the handle and the brake system are working normally.		●
Check the front brake hose.		●
Check the rear brake hose.		●
Check chain cleanliness.		●
Check chain tension.		●
Check chain, front and rear sprockets.		●
Make sure the tire pressure is normal, recommended tire pressure (KPa):		
Single 280/280 (front/rear wheel)	○	●
Double 280/280 (front/rear wheels)		
Check the tire surface for cracks, damage, wear, puncture or adhesion of foreign matter.	○	●
Whether the tread depth is sufficient, deeper than 0.8 mm.	○	●
Check if any error warning lights on the instrument panel after power is turned on.		
Whether the head and tail lights, brake lights, and direction lights are working properly.		●
Check that the horn is working properly.		●
Clean the rearview mirror and adjust it to an appropriate angle.		●

○ one-time cycle

● regular cycle

## 9.2 Recommended Inspections

	every 2 years	
	Every 6000km (3728mi)	
	Every driving 3000km (1864mi)	
Replace front brake fluid		●
Brake fluid after replacement		●
Lubricated Steering Column Bearings		●
Perform fork maintenance		●
after maintenance		●
Change gear oil	●	●
Check cradle bearings	●	●

● Regular cycle

# 10 Vehicle adjustment work

## 10.1 Adjustment of the rebound damping of the front shock absorber



- The hydraulic rebound damping system determines the performance of the fork when it jumps.
- adjustment bolt ◆ is located at the upper end of the fork leg.
- Turn the adjusting bolt fully clockwise ◆.
- Rotate counterclockwise, the number of rotations depends on the different fork types.

Require

rebound damping	
comfortable	18 clicks
standard	12 clicks
sports	6 clicks



### information

When the spring is up, turn clockwise to increase shock absorption, and counterclockwise to decrease shock absorption.

## 10.2 Check the chain tightness



### warning

**ACCIDENT Danger** due to incorrect chain tension.

- If the chain is over-tensioned, it puts additional strain on the components of the secondary drive (chain, motor sprocket, rear sprocket, gearbox, and bearings in the rear wheel). In addition to causing premature wear, in extreme cases it can also wear out the chain, or cause the output shaft of the gearbox to break. Conversely, if the chain is too loose, it can fall off the drive sprocket teeth or the rear sprocket and lock the rear wheel or damage the motor. Observe correct chain tension and adjust if necessary.

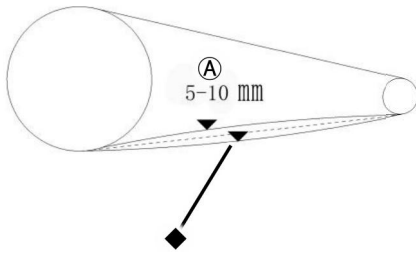

Check the tightness of the chain by pushing up the chain at the lower part of the chain ◆(A) .

Chain tightness(A)	5-10mm
--------------------	--------

If the chain tightness does not meet the regulations.

- Adjust the chain tension. ( see 📖P.30 ) \_

### 10.3 Adjusting the tightness of the chain



warn

**ACCIDENT Danger** due to incorrect chain tension.

- If the chain is over-tensioned, it puts additional strain on the components of the secondary drive (chain, engine sprocket, rear sprocket, gearbox and bearings in the rear wheel). In addition to causing premature wear, in extreme cases it can also wear out the chain, or cause the output shaft of the gearbox to break. Conversely, if the chain is too loose, it can fall off the drive sprocket teeth or the rear sprocket and lock the rear wheel or damage the motor. Observe correct chain tension and adjust if necessary.



#### preliminary work

- Lifting the motorcycle with a lift
- Check chain tightness.

#### The main work

- Loosen the rear axle nuts.
- Rotate the left and right side adjustment bolts ◆ to adjust the position of the left and right chain tensioners ●. Thereby adjust the chain tightness.

Chain tightness	5-10 mm
-----------------	---------

- Make sure the chain tensioner ● is seated against the adjusting bolt ◆ .
- Tighten the rear axle nuts.

rear axle nut	90 Nm
---------------	-------

#### post work

- Remove the motorcycle from the rear wheel stand.

## 10.4 Checking the chain for dirt

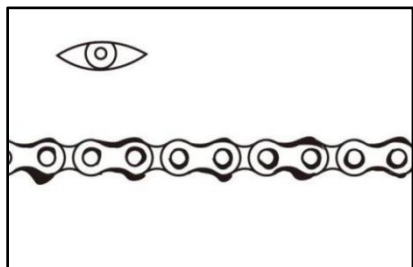

- Check the chain for heavy dirt.
  - » If the chain is heavily soiled:  
Clean the chain.

## 10.5 Cleaning the chain

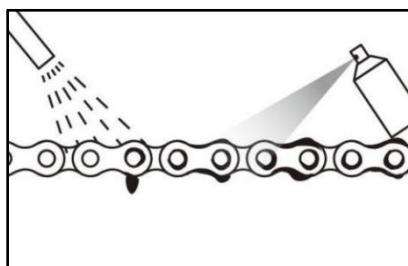

- Lifting the motorcycle with the rear wheel stand
- Clean the chain regularly.
- Rinse off large grime by spraying water.
- Use a chain cleaner to remove used lubricant residue.
- spray chain lubricant after drying.

# 11 Brake system

## 11.1 Checking the brake disc

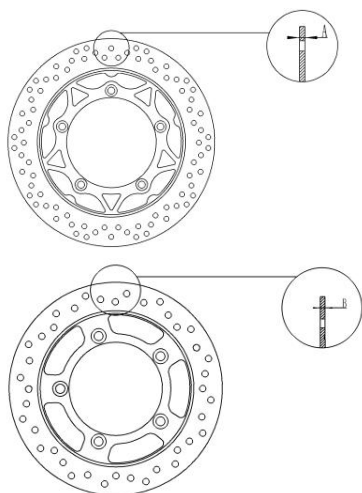

- Check the thickness of the brake disc.

Front brake disc A	$\geq 3$ mm
rear brake disc B	$\geq 3$ mm



### warn

Worn brake discs may weaken braking performance.

- Make sure that worn brake discs are replaced as soon as possible. (Your authorized repair shop will be happy to replace it for you.)



## 11.2 Check brake pads

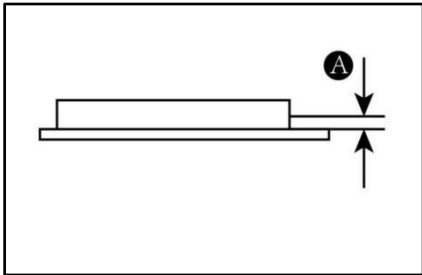
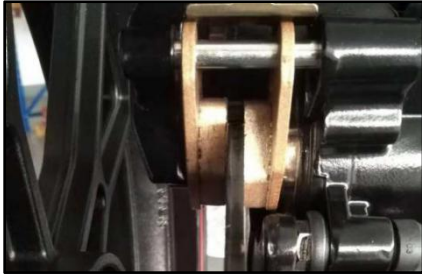

### warn

Worn brake pads may weaken braking performance.  
- Make sure that worn brake pads are replaced as soon as possible.  
(Your authorized repair shop will be happy to replace them for you.)

- View the pads from the top or rear of the rear disc brake lower pump. Visually check the minimum thickness A of the brake pads.

Brake pad minimum thickness A	$\geq 1 \text{ mm}$
-------------------------------	---------------------

- » If the minimum thickness of the friction lining is less than the specified value:

Please replace the brake pads immediately.

- Check the brake pads for damage and cracks.
  - » If damaged or cracked: Replace brake pads.

## 11.3 Checking the brake liquid



### warn

- Insufficient brake liquid can cause brake failure.
- If the brake liquid level is below the LOWER mark, it means that the brake system is leaking or the brake pads are worn.
- Check the braking system and do not continue driving. (Your authorized repair shop will be happy to replace it for you.)



### warn

- Using the brake liquid for too long will reduce the braking effect.
- Change the brake liquid of the front and rear wheel brakes according to the maintenance plan. (Your authorized repair shop will be happy to replace it for you.)



### warn

- Brake fluid may irritate the skin.
- Do not contact skin or eyes, keep out of children.
- Wear protective suit and goggles.

- 
- Do not allow liquid to come into contact with skin, eyes or clothing.
  - If brake fluid is swallowed, seek medical attention immediately.
  - If the brake fluid comes into contact with the skin, wash it off with plenty of water.
  - If brake fluid gets in eyes, rinse thoroughly with water and seek medical attention immediately.
  - If brake fluid gets on your clothes, change them.
- 



- Put the brake fluid cup installed on the handlebar in a horizontal position.
- Check the brake fluid level through the oil cup.
  - » When the brake fluid level drops below the LOWER mark:  
Refill the brake fluid in the front brakes.

## 12 wheels, tires

### 12.1 Check the status of wheels and tires

- Check the wheels for the following items:
  - » Deformation, looseness or wear of tire teeth.
  - » The rim is deformed or cracked.
  - » There are impact marks on the rim.
- Check tires for the following items:
  - » Cuts, cracks, splits, or missing tread patterns in the tread or sidewall area.
  - » There are marks of bumps or bumps on the tires.
  - » Uneven tire tread wear. Wear on one side of the tire's tread or a flat spot on the tread indicates a problem with the tire or motorcycle.

» Tire cord fabric or tire cords are exposed.

- If any of the above conditions are found on the wheels or tires, replace the wheels and tires immediately.

## 12.2 Checking tire pressure



### warn

- Underinflation is a common cause of tire failure and can result in severe tire cracking, tread separation, "blowout" or unexpected loss of control of the motorcycle, resulting in serious injury or death.
- 

Before each ride, tire pressure should be checked and adjusted to the proper inflation level. Tire pressure should be checked with an accurate pressure gauge when the tires are cold. That means those tires haven't been ridden for at least 3 hours. After adjusting the tire pressure, always put the valve cap on.

model	front tire	rear tire
RS1	280 kPa	280 kPa

## 13 batteries

### 13.1 Connecting the battery communication cable

In order to avoid power loss, the communication cable of the battery is not connected when the customer receives the motorcycle, and the customer needs to connect it by himself

The connection steps are as follows



1. Use a hex wrench to remove the three bolts◆ securing the right inner panel



2. The state of the battery communication cable● during transportation is shown in the photo

3. Then connect the battery communication line▲ as shown in the photo



4. Finally put the right inner panel back in place and tighten the fixing bolts

## 13.2 Battery Charging



### Caution:

- When the battery power is lower than 10%, please charge the motorcycle in time
- If the battery is completely discharged, must charge the motorcycle within 24 hours

- We recommend that you charge this motorcycle every day as much as possible within 90 days of purchasing it, even if it is fully charged.
- The battery pack should be kept away from over heat. Li-ion batteries should not exceed 65°C. Do not store in a hot trailer or expose battery packs to direct sunlight.

- Only authorized service agents are qualified to open the inside of the battery pack.
- Dispose of battery packs in accordance with your state and local laws. Encourage recycling of battery packs rather than landfilling them.
- Please contact us at info@tinbot-tech.com or find a recycling center in your area.

### front charging



#### Preparation:

- Place the motorcycle on a level surface.
- Turn off the vehicle.

#### The main work:

- plug the charging gun into the front charging port ◆.
- The battery percentage on the meter of the motorcycle lights up , indicating that it is charging .
- When the meter value reaches 100% , it means the battery is fully charged.

(See  P. 20)

### rear charging



#### Preparation:

- Place the motorcycle on a level surface.
- Turn off the vehicle.

#### The main work:

- charging cable into the charging port ◆ on the lower part of the rear fender .
- Then insert the AC power plug of the charging cable into the mains socket, and the battery percentage of the motorcycle meter will light up , indicating that it is charging .
- When the meter value reaches 100% , it means the battery is fully charged.

(See  P. 20)



### warn

- Pay attention to waterproof to prevent the battery pack from being exposed to water and water intrusion;
- Charging working temperature: 0-45°C, discharging working temperature: -20-65°C;
- The battery pack should be charged whenever it is used. When not in use for a long time, please be sure to remove it from the motorcycle for storage;
- It is strictly forbidden to short-circuit the positive and negative poles of the input and output terminals of the battery pack;
- Keep away from children, fire and heat sources, and strictly prohibit throwing into fire;
- Prohibition of strenuous exercise, impact and extrusion;
- The designated special charger must be used, and it is strictly forbidden to use other chargers to charge the battery pack;
- This product has been strictly inspected before leaving the factory, and it is strictly forbidden to disassemble it by yourself. In case of any problem, please contact the after-sales service department of our company.

## 14 Motor maintenance work

### 14.1 Checking the motor gear oil level





#### Preparation:

- Put the motorcycle on a flat surface.
- Turn off the vehicle.

#### The main work:

- Unscrew the oil dipstick , and use paper towels to wipe off any oil stains on it.
- Insert the dipstick again, but without screwing it in.
- Check the oil level.



- » If the oil level is below the dipstick grid area  :  
Add gear oil.
- » If the oil level is above the dipstick grid area  :  
Replace gear oil.

## 14.2 Replacing the motor gear oil



### warn

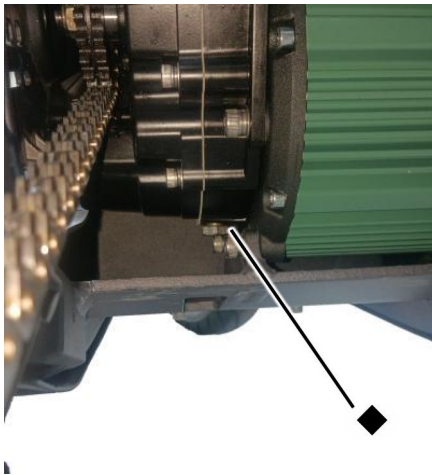

- Gear oil can become very hot when the motorcycle is running.
- Wear suitable protective clothing and safety gloves.
- If you are burned, wash the burn immediately with warm water.



### Preparation

- Park on a flat surface.
- Turn off the vehicle.

### The main work

- Place a suitable container under the motor.
- Remove the oil drain plug  to allow the gear oil to fully flow out.
- Install and tighten the oil drain plug .

Oil drain bolt	M10x1.5x16	20 Nm
----------------	------------	-------



- Remove the oil dipstick.
- Use a special oil pot to add 0.5 L of gear oil.
- Wipe up any spilled oil.
- Install and tighten the oil dipstick.

# 15 Cleaning, maintenance

## 15.1 Cleaning the motorcycle

Cleaning: Please use clean water and neutral detergent to clean, and clean the surface of the vehicle with a soft cloth or sponge; it is strictly forbidden to use metal brushes, sandpaper, etc. to clean, so as not to scratch the surface of the parts. After washing, dry the vehicle with a soft cloth.

---

**!** **Notice**  
Always turn off the main circuit breaker before cleaning.  
Do not wash directly with strong water jets, so as to avoid water vapor intrusion and cause mechanical failure.

---

**!** **Notice**  
Please clean your motorcycle regularly to maintain its value and appearance for a long time.  
Avoid direct sunlight on the motorcycle while cleaning.

---

## 15.2 Inspection and maintenance work during winter use

**!** **Notice**

- If motorcycles are used in winter, consideration must be given to the presence of snowmelt salt on the streets. Therefore, precautions against aggressive deicing salts must be taken.
- Clean your vehicle with cold water after driving on roads sprinkled with snowmelt salt. Hot water may intensify the effects of salt.

---



- Wash the motorcycle.
- Clean the brake system.
- Treat the motor, rocker arms, and all other exposed or galvanized parts (except the brake discs) with a wax-based preservative.
- Clean the chain.

---

**!** **Notice**  
- Preservatives are not allowed to enter the brake disc, otherwise the braking effect will be seriously reduced.

---





### Notice

- After every drive on salted roads, the brake calipers and brake pads should be cleaned thoroughly with cold water after they have cooled down and allowed to dry thoroughly without removing them for cleaning.
- After driving on salted roads, the motorcycle should be cleaned thoroughly with cold water and allowed to dry well.

## 16 storage

### 16.1 Storage

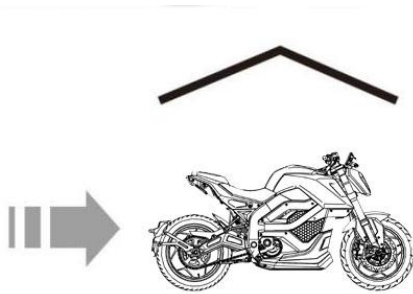

- Try to park it in a dry and cool room to avoid sunlight and rain, so as to avoid the corrosion of parts and shorten the service life.
- For long-term storage, please turn off the air switch and disconnect the battery power supply circuit to prevent the battery from over-discharging.
- After long-term storage, please fully charge the battery before use.
- When the battery pack needs to be stored for a long time, please charge the battery pack to a half-saturated state (after the battery pack is fully discharged, charge it with a charger for 3 hours). Place it in a dry and ventilated place, and charge it with a charger for 2 hours every two months;
- Battery packs and chargers should be stored in a clean, dry, and ventilated place, avoid contact with corrosive substances, and keep away from power sources and heat sources;
- Battery pack storage conditions: ambient temperature  $-20-35^{\circ}\text{C}$ , ambient humidity  $\leq 65\%$ ;
- When storing the charger, please disconnect it from the battery pack.

## 16.2 Preparations before use after storage



### information

If the battery pack has not been used for more than 6 months, first start the vehicle and discharge it until the battery is discharged. Then fully charge the battery pack.

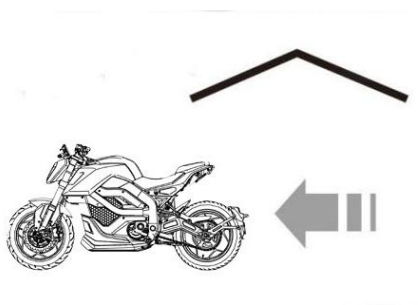

- Install the battery pack.
- Turn on the power.
- Carry out inspection and maintenance measures.
- test ride.

## 17 Fault code table

error code	cause of issue	Solution
Err: ABS01	Sensor power failure	Check sensor cable
Err: ABS02	Front wheel sensor short circuit	Check sensor cable
Err: ABS03	Rear wheel sensor short circuit	Check sensor cable
Err: ABS04	front wheel signal lost	Check sensor cable
Err: ABS05	Rear wheel signal lost	Check sensor cable
Err: ABS06	Motor power disconnect	Check the motor power cable
Err: ABS07	ABS valve short circuit	Check the ABS main line interface
Err: ABS08	ABS circuit break	Check the ABS main line interface
Err:001	Motor Hall failure	Check motor Hall wiring
Err:002	throttle failure	Check or replace the handle

Err:003	Current protection restart	Please stop for a while and start again
Err:004	Phase current overcurrent	Please stop for a while and start again
Err:005	voltage failure	Please contact after-sales service or dealer
Err:007	motor overheating	Please stop for a while and start again
Err:008	Controller overheating	Please stop for a while and start again
Err:009	Phase current overflow	Please contact after-sales service or dealer
Err:010	Phase current zero fault	Please contact after-sales service or dealer
Err:011	Phase short circuit fault	Please contact after-sales service or dealer
Err:012	Line Current Zero Fault	Please contact after-sales service or dealer
Err:013	MOSFET upper bridge failure	Please contact after-sales service or dealer
Err:014	MOSFET lower bridge fault	Please contact after-sales service or dealer
Err:015	Peak Current Protection	Please contact after-sales service or dealer
Err:017	battery temperature failure	Please stop for a while and start again

## 18 Technical parameters

### 18.1 Motor

motor type	Permanent Magnet Brushless DC Motor
rated power	11.0 kW
Maximum power	20.2 kW
Maximum torque	23.3 Nm
Maximum speed	7500 rpm
primary gear ratio	17:33
cooling method	natural air cooling
Gear oil grade	Gear oil (SAE 85W/90)
Gear Oil Capacity	0.5L

## 18.2 Vehicle

<b>total measurement</b>	
Vehicle Dimensions	2130mm x 855mm x 1115mm
Minimum ground clearance	180 mm
seat height	810 mm
<b>speed</b>	
maximum speed	120km/h
<b>quality</b>	
The weight of the whole vehicle with a set of batteries	259kg
The maximum allowable load of the front wheel	141kg
The maximum allowable load of the rear wheel	193kg
The maximum allowable load mass of the vehicle	334kg
quality in operation	126kg
<b>frame</b>	
frame	aluminum alloy
head angle	25°
<b>suspension</b>	
Front suspension travel	110mm
rear suspension travel	35mm
<b>brake system (CBS)</b>	
front brake system	Disc brake (dual piston caliper)
rear brake system	Disc brake (single piston caliper)
Front brake disc diameter	300 mm
rear brake disc diameter	192 mm
Minimum thickness of front brake disc	3 mm
Minimum thickness of rear brake disc	3 mm
<b>tire</b>	
Front tire specification	120/70-17 M/C ,58H
rear tire specification	150/55-17 M/C ,64S
front tire pressure	280
rear tire pressure	280

<b>transmission</b>	
Secondary gear ratio	22:67
Chain Specifications	toothed chain
Number of small sprocket teeth	twenty two
Number of teeth of large sprocket	67

### 18.3 Electrical system

<b>lithium battery</b>	
standard	72V
Full voltage	84V
capacity	117 Ah
weight	58kg
<b>charger</b>	
Input AC voltage	100 ~ 230V
power	1500W
The output voltage	84V
Voltage Converter Output Fuses	10A
USB charging stand fuse	5A
Remote Control Battery Specifications	CR 2032
Headlight	LED 12V 4.8W / 12V 7.4W / 12V 14.8W / 12V 24W
turn signal	LED 12V 4W
rear light	LED 12V 3.1W / 12V 4.7W
rear license plate light	W5W 12V 5W

***WWW.TINBOT-TECH.COM***