

HORWIN CR6 USER MANUAL



HORWIN Headquater

Building No. 33-1 | Hengsheng Science & Technology Park
Beitanghe Rd | Tianning district | Changzhou | Jiangsu
phone.: +86 519 80585808 | email: horwin@horwinglobal.com

European Headquater

Kammersdorf 173 | A-2033 Kammersdorf
phone.: +43 2953 2325 | email: info@horwin.eu
www.horwin.eu

www.horwinglobal.com



www.horwinglobal.com

CR6 User Manual

Welcome to join HORWIN family! We will guide you to understand every function of CR6 electric motorcycle and use CR6 electric motorcycle correctly and safely. To ensure your safety, please read this manual carefully before riding and ensure that you always comply with the following requirements:

Fully understand information in this manual, including but not limited to relevant instructions, precautions and warning information.

Fully understand the operation and emergency measures for CR6 electric motorcycle.

Pay attention to warning labels of CR6 electric motorcycle.

HORWIN will not assume any responsibility arising from unauthorized modification, failure to use original accessories, or installation of components that affect the performance and safety of the motorcycle.

Please contact HORWIN Customer Service Center at service@horwinglobal.com

Should you have any problem on this motorcycle. we will always at your service. Wish you a safe and happy journey!

Safety Instructions

To ensure the safety of you and others, always pay attention to the following matters:

Do not drive after taking medicines that may affect your riding ability, drinking alcohol or in physical discomfort.

Abide by local traffic rules and traffic signs, confirm the surrounding road conditions and vehicle conditions all the time, and actively avoid dangers.

Wear safety equipment such as helmet and appropriate protective clothing such as gloves and boots when necessary.

Before each ride, carry out basic inspection: confirm the lights, brakes, tread, tire pressure, etc.; check whether other parts are loose or have abnormal noise; and have the motorcycle regularly maintained in HORWIN service center.

To ensure the safety of you and other, do not use high beam under good lighting conditions. Continuous use of high-brightness high beam will cause visual interference to vehicles and pedestrians on the opposite side and affect normal driving.

Please do not make or answer calls during the ride to avoid traffic accidents.

Parts and components

Schematic Diagram of Vehicle Body and Components

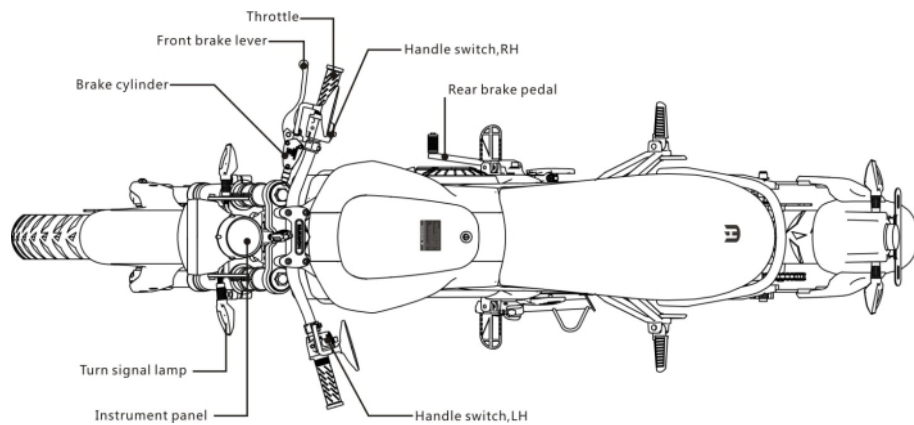
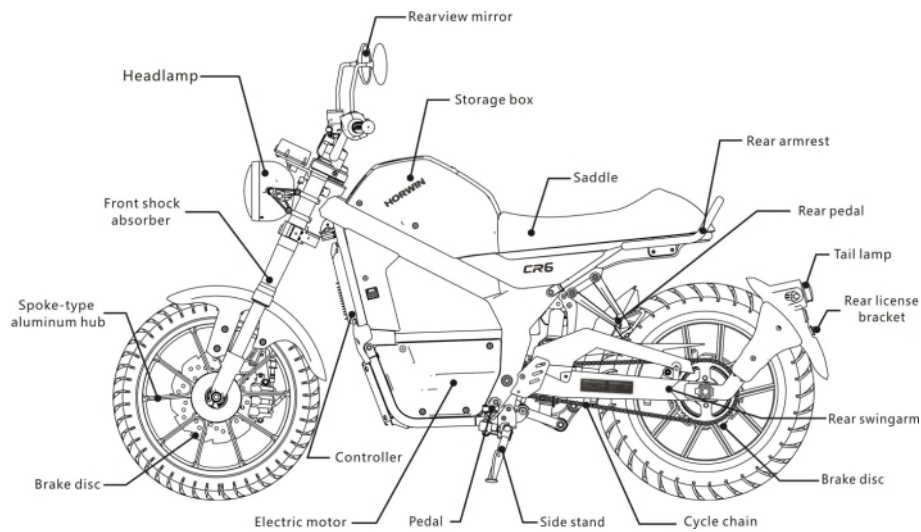

Schematic Diagram of Instrument Board

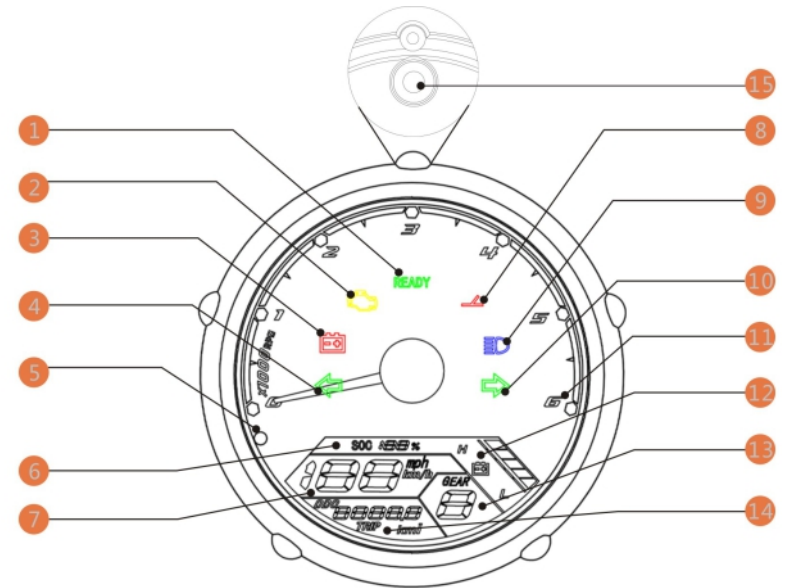

1. Display indicator

Indicates that the vehicle has entered a state ready to ride. Rotate the speed control handle to move the vehicle forward.

2. OBD icon

This icon will light in fault, with fault code shown in mileage display. Display the current ambient temperature.

3. Low battery indicator

This icon will light when the battery level is less than 20%. It will also light when entering charging state.

4. Left turn indicator

Turn on the left turn signal lamp, the indicator flashes.

5. Dial plate luminance automatic sensor

Feel the brightness around all the time, so that the dial plate can adapt to the brightness around.

6. Real-time display of SOC

Display percentage of total battery level up to 100%.

7. Speed display

Display current speed.

8. Lowered side stand indicator battery level display

The indicator will light when the side stand is lowered, at this time, the vehicle is not able to move.

9. High beam indicator

The indicator will light when the high beam is turned on or the passing light button is pressed.

10. Right turn indicator

Turn on the right turn signal lamp, the indicator flashes.

11. Speed indicator

Display the current real time speed of motor.

12. Horizontal bar of power battery level

Display the real time battery level in form of horizontal bar.

13. Gear indicator

Display current gear.

Low speed gear, corresponding to "1".

High speed gear, corresponding to "2".

14. Total mileage

Display the total mileage; when the fault indicator lights, fault code will be displayed. Press the inching button on back of the instrument to switch to trip distance; long press the button to switch between metric system and British system.

15. Metric/British system switching button

Short press once to display trip distance;

When displaying total mileage, long press (2S) to switch between metric system and British system;

When displaying trip distance, long press (2S) to clear the accumulated value of trip distances;

Operation Guidance

Buttons on left handle

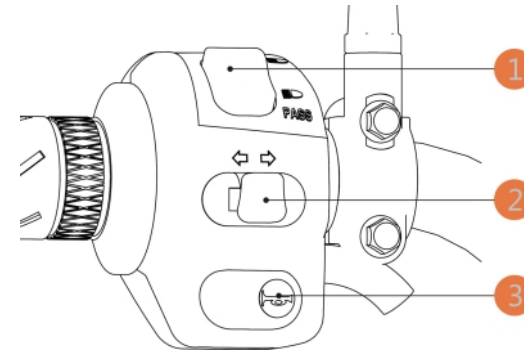

1. High beam/passing beam switch button

Turn on the high beam upward

2. Turn signal lamp button

Push left-ward to turn on the left turn indicator.

Push right-ward to turn on the right turn indicator.

3. Horn button

Press the button to whistle and release to stop.

Buttons on right handle

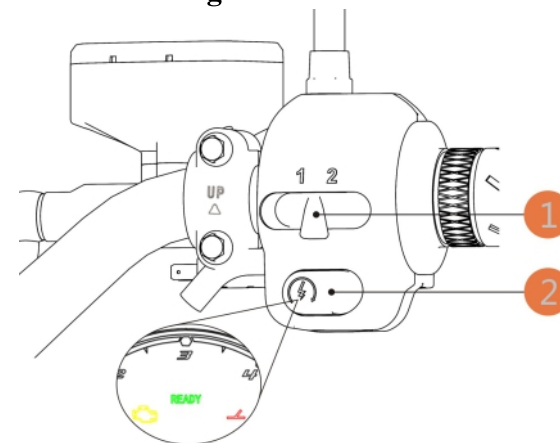

1. Selector button

This bicycle has two modes, i.e.: 1 "eco" mode and 2 "sport" modes. Push left-ward to "eco" mode with maximum speed being 60km/h and right-ward to "sport" mode with maximum speed being 95km/h.

2. Startup button

Press the startup button (with side stand retracted) and the READY lamp on the instrument board will light.

Operation of Smart Remote Controller

With advanced smart remote controller, CR6 electric motorcycle can be locked or unlocked easily by pressing buttons on the remote controller within 30m.

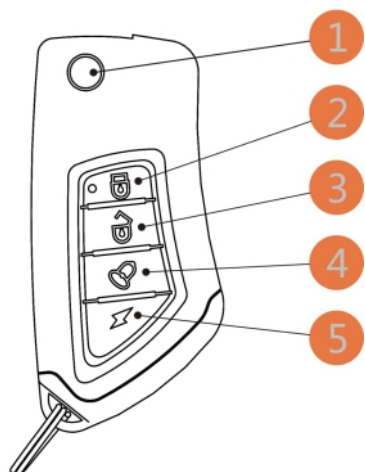

1. Button for physical key. Press to pop out the physical key.
2. Defense button: slightly press to allow the vehicle to enter anti-theft alarm state.
3. Defense cancel button: slightly press to release the vehicle from anti-theft alarm state.
4. Vehicle seeking button: press the button and the vehicle will sound for warning and seeking purpose.
5. Startup button: double click; the vehicle can turn on the whole-vehicle power supply without key.

How to operate physical handle lock

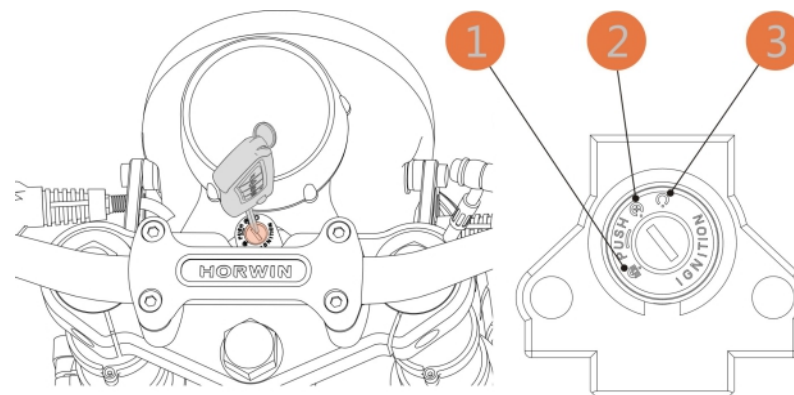

1. After the power is cut off, turn the handle to the most left, insert the key into the physical lock of the head lock, press down and rotate the key to position 1 to lock the head direction lock; turn the key to right directly to the power-off position 2 to start the vehicle.
2. Insert the key into the handle lock and turn right to power-off position 2; the head direction lock can be turned on. At this moment, the electrical system is off.
3. Continue to turn the key right-ward to position 3, the electrical system is on for self-test and the vehicle is stand by.

Open and close the storage box

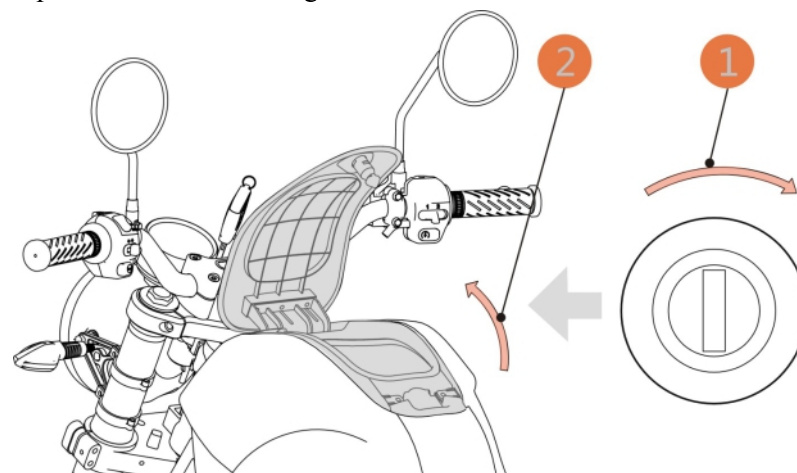

Insert the key and turn 90 degree right-ward, the cover of storage box will be opened upward under its own bounce. There are charging cable and tool kit in the storage box; to close the box, turn the key 90 degree right-ward, press the cover downward and release the key.

Operations to cancel the sea transportation mode

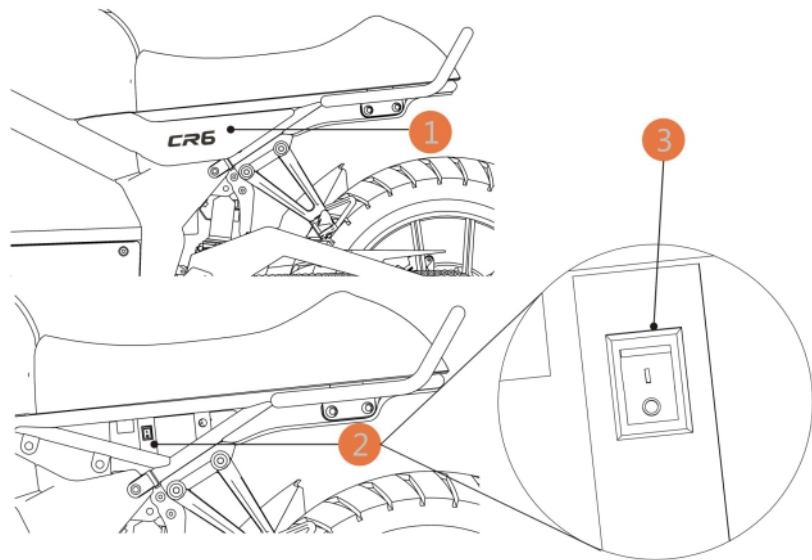

To prevent excessive consumption of electricity during transportation, we set this switch to OFF at the factory, i.e. the "0" position shown. Once you receive the motorcycle, please turn on the switch to position "1" as shown; you will hear a "click" from the center control, indicating that the power is on.

1. Take out the component "1" as shown and pull it outward. There is a triangle choke inserted in the rubber hole.
2. At this moment, you can see the position of the switch for sea transportation mode;
3. Press the button on it to "1" for connection and you can hear a "click" from the center control, indicating that the sea transportation mode is canceled.

Riding Guide

Preparation

Warnings

Drinking is a direct cause of death in motorcycle driving. Every year, 50% of drivers die from driving after drinking. Do not drive after drinking

Before your first drive, we strongly request you to:

Read the user manual;

Confirm that you have fully understood all safety information;

Understand how all control accessories work;

Before your first drive, please confirm that you:

Are in good physical and psychological conditions

Wear helmet (fasten connecting shackle of the helmet and the safety belt), glasses and other protective clothing

Do not drive after drinking or taking medicines;

Protective Clothing

For safety consideration, we strongly recommend that you always wear qualified helmet, glasses, boots, trousers and long sleeves or jackets when driving.

Warnings

In a collision, not wearing a helmet may increase the risk of injury or death. Please make sure to wear helmet, glasses and other protective equipment at all times when driving.

Driver Training

Improving your driving skills is a necessary step at this moment. Even if you have ridden other motorcycles before, you still need to take time to get familiar with the working principle and driving control of CR6. Please practice in a safe place until your skills are mature and you get used to the size and weight of CR6.

We request all drivers to take driving courses certified by local government. New drivers should attend basic training, even experienced drivers can benefit from advanced courses.

Inspection before riding

Cautions

When inspecting CR6, should you find any damage or problem, please correct it or have it corrected with assistance from authorized dealer before riding.

Before riding the CR6 electric motorcycle, please check the following items to ensure your safety on road.

Whether the handle rotates stably and flexibly.

Can left/right handle switch work normally.

Can the speed control handle work normally.

Ensure normal pressure of tire. Suggested tire pressure: 20-25psi for front wheels and 26- 32psi for rear wheels.

Check the tire surface for fracture, damage, wear or foreign matter piercing or adhesion.

Whether the tread depth is sufficient (> 0.8mm).

Is there any fault alarm lamp on the instrument panel on.

Is the battery fully charged.

Can the head lamp, tail lamp, stop lamp and turn signal lamps work normally.

Can the horn work normally.

Are rear mirrors clean. Adjust them to proper angle.

Is the brake oil sufficient. Can handles and brake system work normally.

Should there be any abnormality or operation issue, please contact your Dealer or HORWIN customer service center.

Email: service@horwinglobal.com

Restrictions and Guidelines on Roads

General Information

Cautions

Overloading or improper loading may lead to abnormal motorcycle operation, which may cause serious injury or death. Please follow all load limits and other loading information in this manual

Loading Instructions

The maximum capacity of CR6 is 304KG, including weight of driver and passenger(s), as well as all components of the vehicle body. Your CR6 shall be preferentially used for you and your passenger(s). However, if you want to load more goods, we suggest to use saddle bag. Please check with your dealer about the correct loading method and capacity range of CR6. Improper loading may affect the stability and maneuverability of CR6. Even if your CR6 is correctly loaded, you should drive within safe speed range.

When loading goods, please following the following rules:

Check whether the two tires are properly charged;

If you change your normal load, you may need to adjust the way the goods are hung;

To prevent goods from loosening which may cause hidden danger, please ensure that all goods are firmly bound;

Lower the center of gravity of goods and make it as close as possible to your own center of gravity;

Distribute the weight of goods evenly on two sides of the vehicle body;

How to start riding

CR6 can be started in two ways: by mechanical key and remote controller.

1. Start by mechanical key

Whether it is in anti-theft state or not, CR6 can be started with the mechanical key.

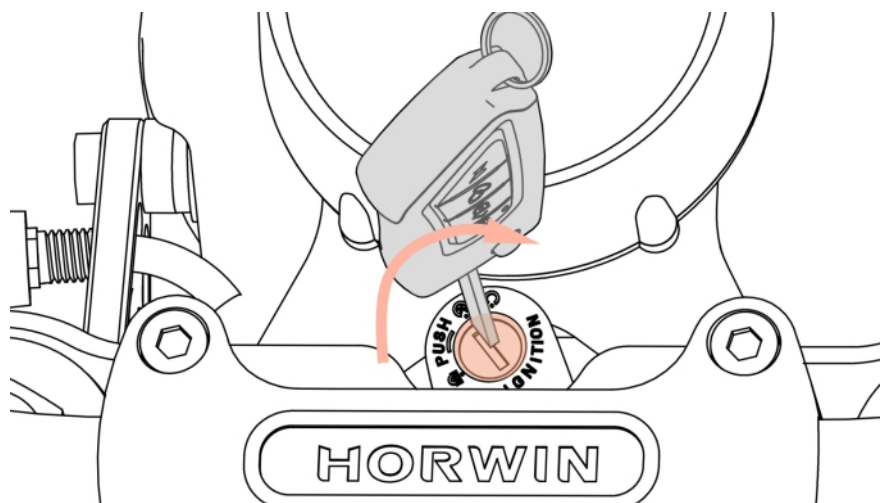

Insert the key and turn right-ward to position 2 to open the vehicle lock. Continue to turn to position 3 to turn on the electric system on the vehicle.

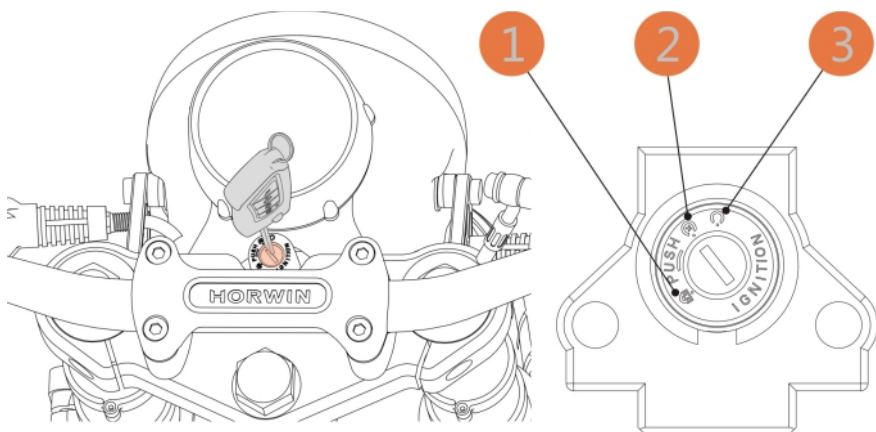

Wear the helmet, get on the motorcycle and fold up the side stand.

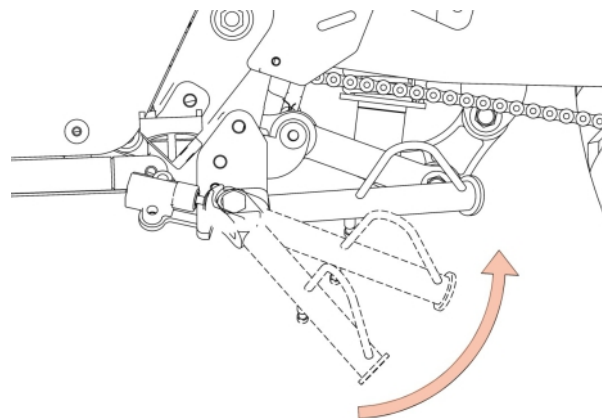

Press the start button 2, the green READY lamp on the instrument panel lights up.

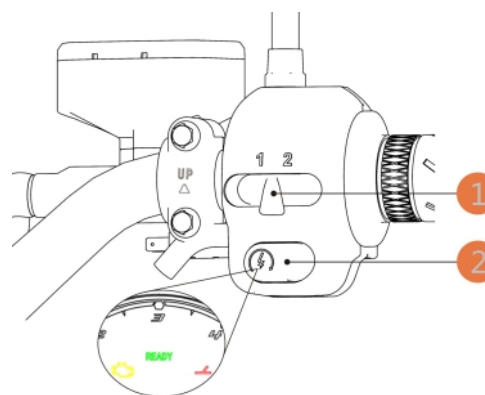

Rotate the right handle slightly, the motorcycle can start. Gear 1 or 2 can be selected on right hand switch according to road conditions.

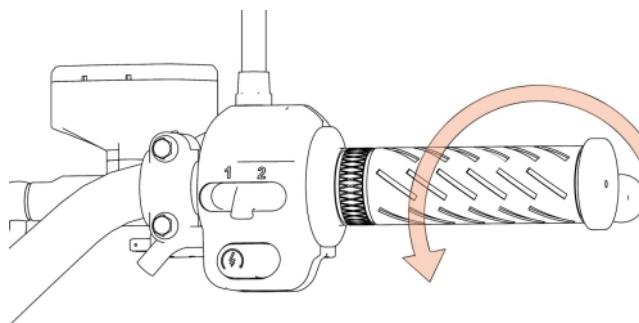

2. Start by remote controller

Press the unlock button 3 on the remote controller and continuously press the start button 5 twice, the electric system of the motorcycle enters standby state.

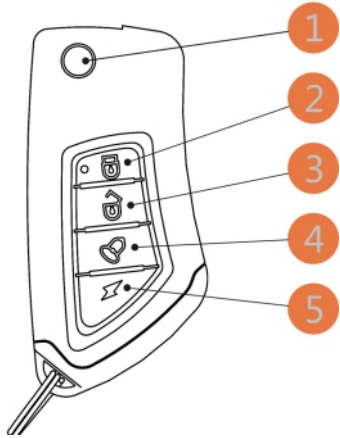

Press the start button 2, the green READY lamp on the instrument panel lights up.

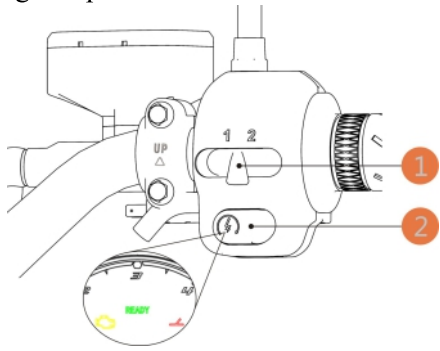

Rotate the right handle slightly, the motorcycle can start. Gear 1 or 2 can be selected on right hand switch according to road conditions.

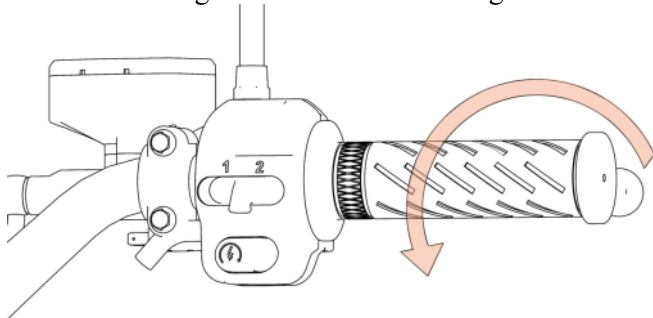

The motorcycle is equipped with a regenerative braking system. When your vehicle is moving without using the throttle, regenerative braking will slow down the vehicle and feed back energy to the HV battery. If you are about to stop, you only need to release the throttle to slow down. You can use the energy obtained from regenerative braking to expand the range of riding.

Braking

The motorcycle is equipped with hydraulically powered CBS front/rear disc brake system. There are two operation manners for rear brake CBS available: pedal type brake on front of the right pedal; brake lever on left of handle. Please pay attention to the selected CBS operation manner when purchasing a motorcycle. Independent front brake is located on right of right handle.

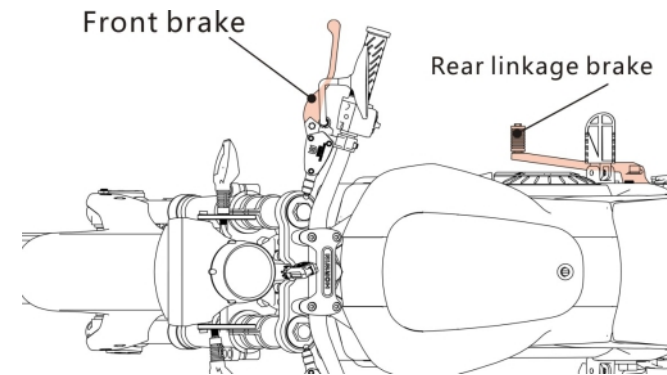
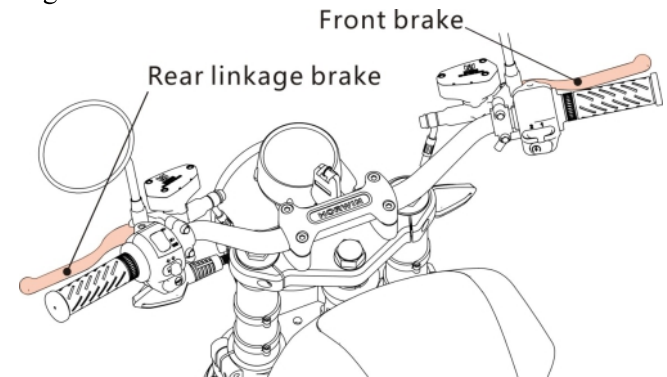

Operate the front or rear linkage disc brake caliper of brake lever.

Lower the caliper on the brake pedal rear disc brake front linkage brake. Normally, the front disc brake system provides 70% of the total braking force. In order to give full play to the braking effect, the brake pedal and brake lever can be used at the same time so that the motorcycle can stop more faster and more stably.

Instructions for Braking

- Excessive sudden braking may cause dead lock and slide of wheel, reducing control over the motorcycle. In this case, release the brake lever and continuously drive forward until the control restores, then brake more gently.
- Decelerate or completely stop before turning as far as possible. Avoid braking in turning which may cause slide of one or two wheels and reduce control over the motorcycle.
- The ability to brake in turning and emergencies is an important riding skill. We suggest taking a safety basic experience training course for motorcycle drivers to obtain these skills.
- When riding in wet or rainy conditions or on soft ground, the maneuverability and braking capacity of motorcycle will be weakened. In this case, all your actions shall be slowed down; sudden acceleration, braking or turning may lead to loss of control over the motorcycle. For your safety, please be careful in braking, accelerating or turning.
- On long steep road section, intermittent use of brake and continuous braking may overheat the brake and reduce its working effect.
- When riding, if your foot rests on the brake or your hand rests on the brake lever, the stop lamp may be turned on by mistake, giving wrong signal to other drivers; this may also overheat the brake and reduce its working effect.

Turning off the Riding System

There are several methods to turn off the riding system:

1. Lower the side stand and the side stand indicator lamp on instrument panel will light up; the whole motorcycle will enter standby state; turning of handle will not move the vehicle.

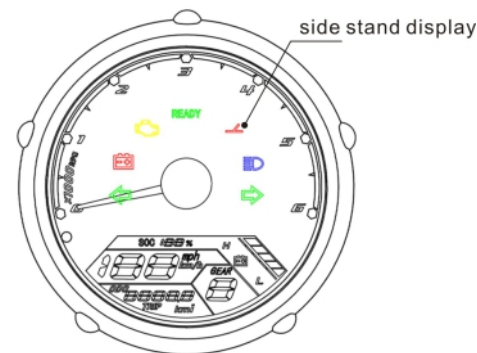
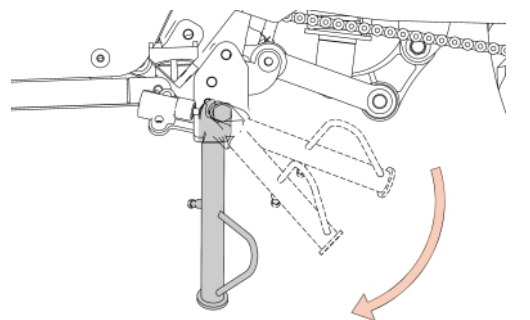

2. If started by key, directly turn the head lock key to position 2 or 1, the whole electric system will be turned off.

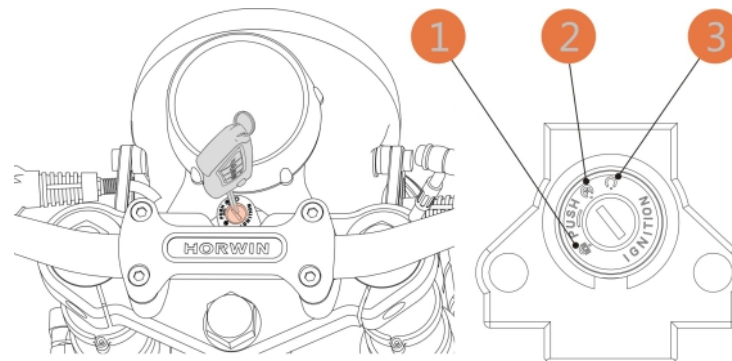

3. If started by remote controller, press the lock key 2 on the controller and the whole electric system will be turned off.

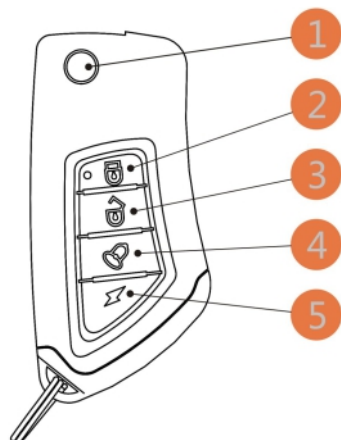

Warm Tips

Before riding, ensure to fold up the side stand and rotate the handle; ensure the handle lock is turned off, i.e. the head lock key is not on position 1.

If the side stand is lowered during riding, the vehicle will be out of power. So, do not stretch out the side stand during riding to avoid sudden power outage which may cause danger.

The vehicle shall be completely stopped before startup. Should there be any abnormality during riding, please ride carefully or push it to safe location. Do not try to re-start the motorcycle during riding to avoid danger.

Anti-theft Instructions

Park the vehicle in a locked garage as far as possible. If there is no garage available, park the vehicle in a hidden or open place with sufficient traffic to prevent theft. Take your car keys with you all the time. Always lock the steering lock, even if you only stop for a minute or two, thieves can easily steal an unlocked motorcycle. In addition to the steering lock, the remote control alarm device equipped on the vehicle shall be locked before leaving. When being moved, the vehicle will alarm for the anti-theft purpose.

Battery Use Instructions

Charging Manner

The vehicle is equipped with on-board charger only

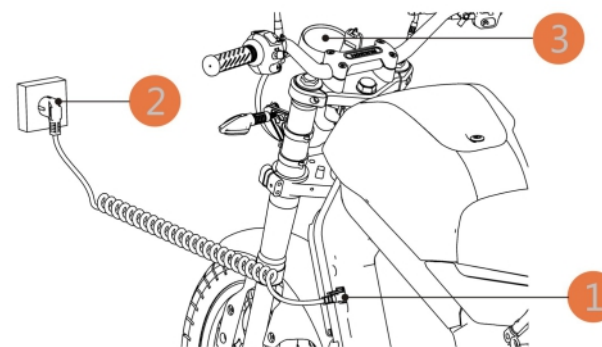

How to charge the battery on-board

1. To prevent ablation of connector, please plug connector 1 of charging cable into the charging port of vehicle.
2. Plug the other end 2 of charging cable into AC power socket.
3. Turn on the switch of AC power socket, you can here a "click"; instrument 3 will with lit and the instrument shows current battery level SOC and charging progress bar.

Tips

Do not expose the battery to water and protect it from damp or rain

Charging temperature is: 0-50°C; discharging temperature: -20-70°C; storage in low temperature environment will reduce the battery capacity;

We suggest charging before the battery level drops to below 20%. If the vehicle is to be idled for a long time, please fully charge the battery; to prevent over discharge of the battery, please charge the battery every month;

Develop good usage habits. Do not jerk the switch frequently; drive at a constant speed.

Do not short-circuit the cathode and anode at the input and output ends of battery;

Keep away from children, fire and heat. Do not put it in fire;

No vigorous movement, impact and extrusion;

This product has been strictly inspected before leaving the factory. Do not disassemble it. Any question please contact our after sales service department.

Storage, Maintenance and Transportation

Please charge the battery to semi-saturation (charge for 3 hours after discharge) for storage or transportation. Place in dry and ventilated place;

The battery and charger shall be placed in clean, dry and ventilated places. Keep away from corrosive substances, power source and heat source;

Storage conditions: ambient temperature: -20-35°C; humidity ≤65% RH;

Maintenance and Repair

Regular maintenance can improve service life and driving safety of CR6 electric motorcycle. Please refer to the following suggestions and take good care of your vehicle.

Daily Cleaning and Maintenance

Rinsing: please rinse with clean water and neutral detergent; clean the surface with soft cloth and sponge; do not use metal brush, sand paper and so on which may scratch the surface. After rinsing, wipe the surface with soft cloth

Tips

Turn off the air switch before rinsing.

Do not flush with strong water flow directly which may cause damage to mechanical parts by water ingress.

Storage method: store in shady, cool and dry rooms as far as possible to reduce exposure to sun and rain, so as to avoid the reduction of service life due to component corrosion.

If idle for a long time, please turn off the air switch, cut off the power line to prevent over discharge.

After long term storage, please charge the battery before use.

Regular Inspection and Maintenance

When a new motorcycle reaches a mileage of 1000 km or service life of two months (whichever comes first), the first inspection and maintenance shall be carried out in the service center.

Regular inspection and maintenance for each 3000km or 6 months (whichever comes first) are recommended in the service center.

Tips

Turn off the air switch before rinsing.

Do not flush with strong water jet directly which may cause fault to mechanical components by damp.

Maintenance Plan

Inspection Item	Odometer/Time (Whichever comes earlier)							
	300mi/500km or 1 month	600mi/1,000km or 2 months	3,000mi/4,800km or 6 months	6,000mi/9,600km or 12 months	9,000mi/14,400km or 18 months	12,000mi/19,300km or 24 months	15,000mi/24,100km or 30 months	18,000mi/28,900km or 36 months
Throttle operation Turning the throttle to ensure stable riding and loose the throttle with a "click" sound to recover 0% starting position	√	√	√	√	√	√	√	√
Chain (*) Inspection to the condition of chain, tightness and coplain Adjustment and lubricating to the chain	Chain could be replaced if necessary after 300miles riding in moist, dirt or after cleaning.							
Front brake Inspection to brake pump oil and leakage	√	√	√	√	√	√	√	√
Rear brake Inspection to brake pump oil and leakage	√	√	√	√	√	√	√	√
Braking system Inspection to pipe, disk thickness and bolt	√	√	√	√	√	√	√	√
Replacement to braking fluid (**)				√		√		√
Gear oil (*) Replacing " GL-5 85W/90" oil		√	√	√	√	√	√	√
Braking light Inspection to working condition	√	√	√	√	√	√	√	√

Signal light and head light (*) Inspection to working condition	√	√	√	√	√	√	√	√
Side stand Inspection to working condition	√	√	√	√	√	√	√	√
Front suspension Inspection to leakage	√	√	√	√	√	√	√	√
Replacement to front suspension hydraulic oil (**)							√	√
Fastener (*) Inspection to all fasteners and connecting parts Strengthening and adjustment if necessary	√	√	√	√	√	√	√	√
Tire Inspection to tire pressure Inspection to the depth of tire tread, replacement for font less than 1.5mm and rear 2.0mm Inspection to wearing	√	√	√	√	√	√	√	√
Rim (**) Inspection to roundness and dent Replacement if necessary	√	√	√	√	√	√	√	√
Turning bearing (*) Inspection to loose	√	√	√	√	√	√	√	√
Battery Inspection to breakage or dent	√	√	√	√	√	√	√	√
Motor (**) Inspection to working condition Inspection to wire and cable	√	√	√	√	√	√	√	√
Items marked (*) should be operated by HORWIN authorized distributor, unless proper tool, service date or mechanic qualification is applied. Items marked (**) should be only operated by HORWIN authorized distributor for the sake of security.								

Frequent Problems and Elimination Methods

Fault	Inspection Steps	Problem Analysis	Solution
Turn the key and the instrument does not light	1. Turn the key; lamps and instrument do not light	DC-DC damage/open switching circuit	Replace the DC-DC/sent out for repair
	2. Lamps and the instrument panel do not light; when started by wireless key, lamps on the instrument panel light	If the instrument panel and lamps light, the key switch circuit is open; if the instrument panel lights but lamps fail, the DC-DC is damaged	Replace the DC-DC/sent out for repair
	3. When turning the key, listen to whether there is a startup sound from the central control/whether the wheel can rotate by pressing the READY key if the instrument panel does not light	If there is no startup sound and lamps light, the center control crashes or is damaged	Turn off the sea transportation switch for 30s; then turn on and restart; if it is not possible, replace the center control/send out for repair
		If the wheel can rotate by pressing the READY key with the instrument panel not lighting, the center control crashes or is damaged	
		If there is startup sound and lamps light, the instrument panel is damaged/IO port output of center control is damaged	Replace the instrument panel or center control/send out for repair

Turn the key, the instrument lights but buttons can not enter the READY state	Turn the key and listen to whether there is a "click" from the center control	If yes, the circuit is open; if no, the electronic control is damaged	Send out for repair
Turn the key; there is READY shown but no response from handles	Check whether the stop lamp is highlighted	If yes, the brake switch is closed; if not, the electronic control is abnormal	Open the brake switch/send out for repair
Turn the key and there is no any response	Charge the battery	Battery protection/battery damage/open circuit	Reset the battery charging/send out for repair
Buttons of wireless key do not work	1. Check whether the wireless key has electricity 2. If yes, press buttons in a shorter distance to see whether there is response	1. The wireless key is lack of power 2. If no response, the antenna module of center control is damaged; if there is response, the remote control and center control fail to match well	Replace the battery of wireless key/send out for repair
The instrument panel shows 12289	Anti-galloping fault	Release the handle and turn on the key again or contact the after sales service or dealer	
The instrument panel shows 12290	Pre-charge fault	Turn on the key again or contact the after sales service or dealer	

The instrument panel shows 12291	Over-current of controller	Turn on the key again or contact the after sales service or dealer	
The instrument panel shows 12292	Over-temperature of electronic control	Wait for a while to allow nature cooling or contact the after sales service or dealer	
The instrument panel shows 12293	Relay loss	Contact the after sales service or dealer	
The instrument panel shows 12294	Current sampling fault	Contact the after sales service or dealer	
The instrument panel shows 12295	Coder fault	Contact the after sales service or dealer	
The instrument panel shows 12296	Undervoltage of battery bank	Restore charging or contact the after sales service or dealer	
The instrument panel shows 12297	Overvoltage of battery bank	Turn on the key again or contact the after sales service or dealer	
The instrument panel shows 12298	Overheat of motor	Wait for a while to allow nature cooling or contact the after sales service or dealer	
The instrument panel shows 12299	Handle fault	Please check the handle wire or replace in after sales service	

The instrument panel shows 12300	Communication fault	Please check whether the controller interface is correct, or contact the after sales service or dealer	
The instrument panel shows 12545	Over-high total voltage	Pull out the charging cable, turn on the key to power on, or contact the after sales service or dealer	
The instrument panel shows 12546	Excessive low total voltage	Restore charging or contact the after sales service or dealer	
The instrument panel shows 12547	Over-high unit voltage	Pull out the charger, turn on the key to power on, or contact the after sales service or dealer	
The instrument panel shows 12548	Excessive low unit voltage	Restore charging or contact the after sales service or dealer	
The instrument panel shows 12549	Excessive unit voltage difference	Turn on the key again or contact the after sales service or dealer	
The instrument panel shows 12550	Over-high charging temperature	Pull out the charger and wait for cooling down	

The instrument panel shows 12551	Excessive low charging temperature	Park the vehicle indoor or in warm place and wait for a minute	
The instrument panel shows 12552	Excessive low insulation resistance	Turn off the key to reset or contact the after sales service or dealer	
The instrument panel shows 12553	Over-high discharging temperature	Wait for a while to allow nature cooling or contact the after sales service or dealer	
The instrument panel shows 12554	Excessive low discharging temperature	Park the vehicle indoor or in warm place and wait for a minute	
The instrument panel shows 12555	Excessive charging temperature difference	Stop charging or contact the after sales service or dealer	
The instrument panel shows 12556	Excessive discharging temperature difference	Stop discharging or contact the after sales service or dealer	
The instrument panel shows 12557	Excessive discharging current	Turn off the key or restore charging	
The instrument panel shows 12558	Excessive charging current	Stop charging and discharge	
The instrument panel shows 12559	Primary over discharge	Restore charging	
The instrument panel shows 12560	Cable core loses connection	Turn off the key to reset or contact the after sales service or dealer	

The instrument panel shows 12561	Charging mos is damaged	Contact the after sales service or dealer	
The instrument panel shows 12562	Discharging mos is damaged	Contact the after sales service or dealer	
The instrument panel shows 12563	Cable core temperature sensor fails	Contact the after sales service or dealer	
The instrument panel shows 12564	Over-temperature of charging mos	Stop charging or contact the after sales service or dealer	
The instrument panel shows 12565	Over-temperature of discharging mos	Stop discharging or contact the after sales service or dealer	
The instrument panel shows 12566	Protection IC fails	Contact the after sales service or dealer	
The instrument panel shows 12801	Hardware fault	Contact the after sales service or dealer	
The instrument panel shows 12802	Over-temperature of charger	Stop charging or contact the after sales service or dealer	
The instrument panel shows 12803	Wrong input voltage	Select voltage matching the charger for charging	

Warranty Registration Form

Year:		Model:	
VIN NO:			
Motor No.:			
Date of purchase:			
User name:			
User address:			
User contact number:			

Note: This form is filled in by the user and the dealer tears down the record.

Policy of Warranty

Thanks for purchasing CR6 electric motorcycle produced by HORWIN®. In order to provide full range of warranty service for all users, following specific provisions are given out according to relevant laws and regulations:

The warranty period of main parts (frame, motor, battery) is 24 months or 20,000 km, whichever comes earlier. The warranty of other parts shall be carried out according to Warranty Standards.

Within the warranty period, HORWIN distributor/dealer in the territory will provide free repair or replacement. Beyond the warranty period or the warranty range, HORWIN distributor/dealer will provide paid service.

For the sold products, the warranty period starts from the date of signature for express delivery.

Warranty Standards of Spare Parts

Spare Parts	Warranty Standard	Warranty Exemption	Warranty Period
Lithium Battery Pack	The voltage abnormalities, charge failure, less-than-60% capacity and other malfunctions of the lithium battery which is used after charged in the required environment and not subject to external impacts. (The 3-guarantee period of replaced battery is not re-calculated, which means that after replacement, the warranty period of battery is calculated according to the remaining warranty period of the original battery.)	Damage to the internal cell connections caused by unauthorized dis-assembly of the battery pack (As the internal cell connections of the battery pack are complex, consumers are not recommended to take the battery pack apart by themselves.)	24 Months or 20,000km, whichever comes earlier. (The battery can be replaced with a new one within the first 3 months or 5,000 km and a maintained one in the later 21 months. If ECU is replaced or the lithium battery pack is purchased separately, the validity term of the Three Guarantees is 24 months, and not calculated by the mileage.)
Electric Motor	Quality problems like open phase or burn-out of coil, demagnetization or loss of magnetic steel and so on, which cannot be repaired.	1. Damage to internal circuit of motor caused by unauthorized dis-assembly 2. Breakage of the motor from artificial factors	24 Months or 20,000 km whichever comes earlier

Spare Parts	Warranty Standard	Warranty Exemption	Warranty Period
Frame	<ol style="list-style-type: none"> 1. Loss weld, incomplete and missing welding of the weld joints 2. Cracks in key parts, or frame fracture 3. Failure to apply license plate due to the unclear frame code printing 	<ol style="list-style-type: none"> 1. Damage caused by human factors or improper use 2. Unauthorized modifications of frame structure 3. Unauthorized modifications of body structure 	24 Months or 20,000 km whichever comes earlier
Sub-frame	<ol style="list-style-type: none"> 1. Loose weld, incomplete and missing welding of the weld joints 2. Deformation or cracking caused by quality problems of frame 	<ol style="list-style-type: none"> 1. Damage caused by human factors or improper use 2. Unauthorized modifications of frame structure 3. Unauthorized modifications of body structure 	12 Months
Instrument	<ol style="list-style-type: none"> 1. No display or incomplete display of the LCD instrument panel 2. Inaccurate digit hopping of the LCD instrument panel 3. The abnormal display of date 	Scratches or damage to instrument from human factors	12 Months

Spare Parts	Warranty Standard	Warranty Exemption	Warranty Period
Charger	<ol style="list-style-type: none"> 1. Charge failure caused by charger line defects 2. No change in charging indicator 	<ol style="list-style-type: none"> 1. Modifications of internal structure or lines 2. No errors after testing 	12 Months
Converter	<ol style="list-style-type: none"> 1. Internal damage, or voltage regulation failure 2. No DC output, or over supply voltage 	No errors after testing	12 Months
Controller	<ol style="list-style-type: none"> 1. Internal damage, or voltage regulation failure 2. DC output failure, or over supply voltage 	Damage resulting from unauthorized modifications of the internal circuit or structure of the controller	12 Months
Main wire harness	<ol style="list-style-type: none"> 1. Short circuit, open circuit, ablation and other problems during correct use that cannot be repaired (caused by the main wire harness defects) 2. Circuit defects not caused by improper installation 	<ol style="list-style-type: none"> 1. Unauthorized modifications of the circuit or artificial damage 2. Tear or wear of the cable surface (Non-body structure problems) 	12 Months

Spare Parts	Warranty Standard	Warranty Exemption	Warranty Period
Central control	<ol style="list-style-type: none"> 1. Communication fault 2. Port output fault 3. Phonetic function fault 4. Wireless key fault 5. System halt 	<ol style="list-style-type: none"> 1. Damage resulting from unauthorized repairing 2. Unauthorized modifications 3. Improper operation or use 4. Damage from resulting from abnormal environment condition 5. Damage resulting from human factor or irresistible natural disaster 	12 Months
Handlebar	<ol style="list-style-type: none"> 1. Uneven heights of the handlebar at its both ends 2. Different lengths of the handlebar on both sides 3. Crack, fracture 	Deformation or damage due to human factors or improper use	12 Months
Steering column	<ol style="list-style-type: none"> 1. Loose weld between direction column riser and upper connecting plate 2. Crack, fracture 	Deformation or damage due to human factors or improper use	12 Months

Spare Parts	Warranty Standard	Warranty Exemption	Warranty Period
Rear swingarm	Fracture, loose weld	<ol style="list-style-type: none"> 1. Damage due to human factors or improper use 2. Alterations of status by consumers 	12 Months
Shock absorber	<ol style="list-style-type: none"> 1. Fracture of base cylinder fork tube under the normal use of front shock absorber 2. Serious oil leakage in the oil seal of front shock absorber 3. Oil leakage of rear shock absorber, loose weld of joints 4. Fracture on the piston rod of rear shock absorber damper 	<ol style="list-style-type: none"> 1. Oil leakage caused by significant damage due to improper use 2. The parts have been replaced, removed and cannot be restored 3. Obvious bumps of shock absorber 4. Soft or hard shock absorber (due to human factors) 5. Rod deflection of rear shock absorber caused by self-modification or overload 	12 Months

Spare Parts	Warranty Standard	Warranty Exemption	Warranty Period
Wheel hub	<ol style="list-style-type: none"> 1. Peeling or fracture of the wheel rim of the hub 2. Quality problems of front hub that cause the disc brake stuck and fail to rotate 3. Fracture of hub 4. Deformation of the hub wheel 	<ol style="list-style-type: none"> 1. Hub deformation and scratches or damage due to improper maintenance and overload use 2. Deformation caused by collision 	12 Months
Rear handrail	<ol style="list-style-type: none"> 1. Rust of plating layer 2. Plating layer detachment, fracture 	<ol style="list-style-type: none"> 1. Damage from improper use, scratch, crash, or overload 2. Deformation from crash 	12 Months
Horn	Malfunction caused by structure and quality problems of the horn	No errors after testing	12 Months
Full-day lock	<ol style="list-style-type: none"> 1. The front lock failure 2. Battery lock failure 3. Remote control failure 	<ol style="list-style-type: none"> 1. Full-day lock is broken by picklock with iron unit. 2. Improper use leading to lock body damage 	12 Months

Spare Parts	Warranty Standard	Warranty Exemption	Warranty Period
Brake system	<ol style="list-style-type: none"> 1. Breakage or falling off due to material problems 2. Brake failure of hydraulic braking system caused by leakage of gas, air resistance, decreased pump pressure, or brake caliper seizing 3. Brake uninterrupted and cannot be repaired 	<ol style="list-style-type: none"> 1. Oil leakage due to inappropriate removal over upper and lower pump assembly of hydraulic disc brake 2. Malfunction of hydraulic disc brake just because of lack of oil instead of its damage 3. Wear of brake disc 4. Brake system damage caused by self-modification 	12 Months
Throttle	Unable to adjust speed due to circuit and structural problems	Abnormal use causes the throttle to not work properly	12 Months
Headlight	Malfunction caused by the quality problem of headlight	Headlight damage caused by unauthorized circuit modification	12 Months
Taillight	Malfunction caused by the quality problem of taillight	Headlight damage caused by unauthorized circuit modification	12 Months

Spare Parts	Warranty Standard	Warranty Exemption	Warranty Period
Turn light	Malfunction of turn light caused by quality problem	Damage of turn light caused by artificial circuit modification	12 Months
Rear license light	Malfunction of rear license light caused by quality problem	Damage of rear license light caused by artificial circuit modification	12 Months
Left and right switch assembly	<ol style="list-style-type: none"> 1. Switch failure and failure to be in place or reset 2. Loose and breakage of switch button because of the quality problems 3. Short circuit, open circuit or poor contact inside switch 4. Inconsistent switch circuit 	<ol style="list-style-type: none"> 1. Unauthorized circuit modifications 2. Missing pieces or inconsistency 	12 Months

Spare Parts	Warranty Standard	Warranty Exemption	Warranty Period
Side stand	Fracture or loose weld	<ol style="list-style-type: none"> 1. Deformation or damage due to human factors or improper use 2. Scratches or damage to surfaces by human factors 3. Self-modification or self-repair such as welding, etc 	12 Months
Saddle	Cushion quality problems causing open line or cracking	Breakage and fracture of the saddle surface by human factors	6 Months
External plastic parts	If the area of peeling or crack that caused by the paint problem is one CM ² or more, the part can be replaced.	Damage caused by human factors	12 Months
Air switch	Automatic disconnect protection failure under over-voltage or over-current	No errors after testing	6 Months
Tire	Cracking, swelling or broken line	<ol style="list-style-type: none"> 1. Normal wearing 2. Damage caused by human errors 3. External damage 	1 Month

Instructions to other items not covered by warranty standard

- Based on the above table, the items or conditions that are not within the time limits and scope of the three guarantees provisions will not be applied to the "Three Guarantees" service.
- Bulbs, brakes pad, motor hub cover, rearview mirror, brake cable, screw nuts and other standard parts, decorative pieces, black pieces, pedal rubber, chain, chain supporting, bearings, chain guide, switch, gas nozzle and other vulnerable parts are not covered by the three guarantees.
- Normal maintenance services, including but not limited to: replacing gear oil, checking tires, checking brakes, adjusting brakes, changing brake fluid, checking electrical system, checking chain tension, adjusting chain tension, replacing chains, checking battery packs are not within the scope of the "Three Guarantees".
- Advertising promotions, gift items, loudness of the sound, soft and hard feelings and other items related to sensory perception.
- The vehicle is damaged due to force majeure, such as smoke, earthquake, typhoon, flood, fire, lightning, chemical corrosion etc.
- Failure to repair in service provider, self-modification, dis-assembly, destruction of parts; use of non-original parts that causes damage to other parts, and unauthorized modification of the circuit and configuration are not covered in the Three Guarantees.

- Damage caused by crash, falling down, over-speed, overload, unauthorized modification, failure to use the original parts, failure to follow instructions in user manual and other human factors.
- Without invoice, warranty card, or discrepancy between the invoice/card and the product.
- Controllers, chargers and other parts whose trademarks or seals are artificially torn up will not be covered.

Repair & Maintenance Records

In order to enhance your warranty experience, please be sure to repair and maintain your vehicle at our authorized dealers. And please record in the form below and stamp the dealer's seal.

Model:	Frame No.:	Motor No.:
The 1st service Date: Range:	Dealer's stamp	
The 2nd service Date: Range:	Dealer's stamp	
The 3rd service Date: Range:	Dealer's stamp	
The 4th service Date: Range:	Dealer's stamp	
The 5th service Date: Range:	Dealer's stamp	

The 6th service Date: Range:	Dealer's stamp
The 7th service Date: Range:	Dealer's stamp
The 8th service Date: Range:	Dealer's stamp
The 9th service Date: Range:	Dealer's stamp
The 10th service Date: Range:	Dealer's stamp
The 11th service Date: Range:	Dealer's stamp

The 12th service Date: Range:	Dealer's stamp
The 13th service Date: Range:	Dealer's stamp
The 14th service Date: Range:	Dealer's stamp
The 15th service Date: Range:	Dealer's stamp
The 16th service Date: Range:	Dealer's stamp
The 17th service Date: Range:	Dealer's stamp

The 18th service Date: Range:	Dealer's stamp
The 19th service Date: Range:	Dealer's stamp
The 20th service Date: Range:	Dealer's stamp