

SOCO
INNOVATION

TS
STREET
HUNTER

E-Scooter User Manual

Do not operate the electric vehicle until you have read the user manual carefully and understand the performance of the electric vehicle, and please keep the user manual in a safe place.

USER INSTRUCTION

To ensure your safety, please read this manual carefully before riding and make sure you are always following the requirements below:

- 1 Fully understand the information in this manual, including but not limited to the relevant instructions, precautions and warnings.
- 2 Fully understand the operation and contingency measures of TS Smart Electric Scooter.
- 3 Be fully aware of warning labels of TS Smart Electric Scooter.
- 4 Do not disassemble the vehicle or any parts without permission. Please contact customer service department and dealers if you need any replacement or make further purchase.
- 5 Please keep the user manual in a safe place.



All parameters of this vehicle have been permanently set according to the national standard before leaving factory. The company is not responsible, if the original electrical or circuit has changed and caused excess, such as increase the speed.

SAFETY INSTRUCTION

To ensure the safety of you and others, please make sure to observe the following:

- 1 Don't lend your vehicle to someone who can't operate it to prevent any hurts.
- 2 Please obey local laws and regulations while operating the vehicle on the road.
- 3 Do not ride on the road after taking medications, drinking alcohol or when you feeling unwell which may affect your riding ability.
- 4 Observe traffic regulations and traffic signs, according to the provisions of laws and regulations to carry man and cargo. Confirm the surrounding road conditions and vehicle condition any time to actively avoid danger.

SAFETY INSTRUCTION

- 5 In rainy and snowy weather, braking distance will be extended, please slow down the vehicle. Avoid travelling in bad weather such as storms and typhoons.
- 6 Wear safety gears, especially helmet. Wear appropriate protective clothing like boots and gloves if necessary.
- 7 To ensure the safety of you and others, please avoid using the high beam under good lighting conditions. The continuous use of high beam will cause visual obstacles to opposite vehicles and pedestrians and affect the safe driving. In the case of dim light, turn on the lights in time.
- 8 Please turn off the power immediately and remove the key after riding. Do not allow children play the vehicle to avoid unnecessary losses.
- 9 Perform a basic check each time before riding.
- 10 Please pay attention to the safe operation of the electric vehicle:
 - a) Do not park the vehicle indoors or in the hallway.
 - b) Do not charge the battery/vehicle indoors or in the hallway. The battery/vehicle should be kept away from combustible materials when charging, and the charging time should not be too long.
 - c) Please pay attention to the correct usage of the battery and warning labels. Wasted batteries should not be dismantled without authorization, and should be managed and recycled by the relevant professional departments.
 - d) Please pay attention to the safe usage and the warning labels of the charger. Make sure to use the original charger for the same model.
 - e) Please be aware of the precautions regarding water washing.
- 11 Check before riding, if there is an abnormality, please promptly carry out maintenance or find professional repair service:
 - a) Check the status of power circuit, lighting circuit, etc.
 - b) Check whether the front and rear brakes work properly.
 - c) Check whether the handlebars, front and rear wheels are stable.
 - d) Check tire pressure.
 - e) Check whether the reflectors are stained.

- 01 -

ACCESSORIES CHECKLIST



× **2**

Intelligent Remote Control



× **1**

Rearview Mirrors



× **1**

Quick Start



× **2**

Key



× **1**

Wrench for Rearview Mirror



× **1**

Charger

- 02 -

INSTALL BATTERY PACK

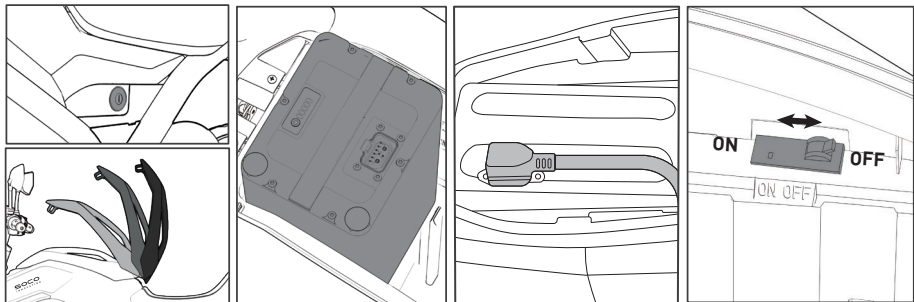

- 1** Open the storage box cover.
- 2** Remove the storage box.
- 3** Put in the battery pack, and plug in the main plug.
- 4** Turn on the air circuit-breaker, put in the storage box, and close the cover.

QUICK START

- 03 -

STARTING VEHICLE

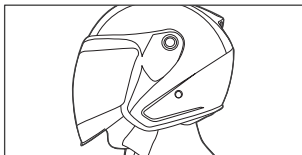

- 1 Put on the helmet.

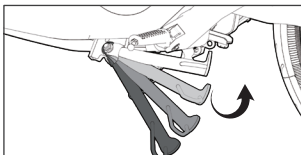

- 2 Get on your TS, retract the side stand and center stand.

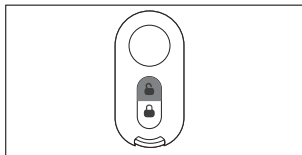

- 3 Press "Unlock" button on the intelligent remote control.

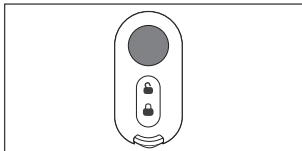

- 4 Press "Power" button on the intelligent remote control.

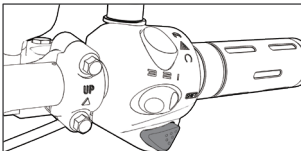

- 5 Press the "Parking" button, apply the brake to unpark the vehicle, parking indicator turns off.

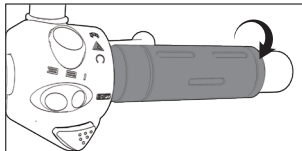

- 6 Gently twist the throttle to ride on the road.

Note: When the vehicle remains stationary for a long time in power-on state, it will switch to the parking state. Gently hold the brake, and the power will be on again.

- 04 -

DOWNLOAD APP

TS intelligent electric motorcycle supports wireless communication, GPS, etc., which can connect the vehicle with your smart phone. You can manage and check your vehicle using your smart phone through the SOCO App.

Available on **iOS** and **Android** platforms, please check your smart phone operating system before installation.

iOS platform: App requires **iOS 9.0** or later.

Android platform: App requires **Android 4.4** or later.

Download and install SOCO App by scanning the QR code in the last page of this manual.



SOCO APP

Since the date of purchase, you will be presented with 1 year's free data of SIM card to use SOCO APP function. Make sure to recharge it before the free period expires. For those who fail to recharge within the time limit, the operator will close the recharge interface, and the recharge function of data cannot be restored, in which case SOCO APP cannot be used normally.

PARAMETER TABLE

Main Specifications and Performance Index for TC WILD WANDERER

Main Specifications	LxWxH (mm)		2038x788x1085	
	Wheelbase (mm)		1325	
	Carrying Capacity (including the driver) (person)		2	
	Rated Capacity (kg)		150	
	Head Angle (°)		25	
	Tire	Front	100/80-17	
		Rear	120/70-17	
	Max Speed (km/h)		75 (I3e) 45 (I1e)	
	Climbing Capacity (°)		14	
Ground Clearance (mm)		170		
Main Weight Parameters			Total Weight of the Vehicle	Rated Maximum Load
	Total Weight (kg)		102	266
	Front Wheel Axle Load (kg)		48	85
	Rear Wheel Axle Load (kg)		54	181
Controller Main Specifications	Model		ZWK060065A/ZWK060065A-B	
	Overcurrent Protection Value(A)		65±1	
	Undervoltage Protection Value(A)		51±1	

PARAMETER TABLE

Motor Main Specifications	Model	17ZW6064338YA
	Motor Type	Permanent Magnet
	Rated Continuous Power Output (kw)	2500
	Rated Rotating Speed (r/min)	640
	Rated Output Torque (N.m)	38
Battery Main Specifications	Type	Lithium Battery
	Specification	60V32Ah
	Total Voltage	60
	Total Capacity	32
Electrical System Main Specifications	Headlight Specifications	LED
	Brake Light/Rear Position Light Specifications	LED
	Turn Signal Light Specification	LED
	Front Position Light Specifications	LED
	Air circuit breaker Specifications	80
Charger Main Specifications	Type	60V10A
	Voltage	60V
	Output Current	10A

CONTENTS

Description of Components and Parts	10
Operation Guide	15
Riding Guide	20
Battery use Instructions	23
App Instructions	26
Maintenance	27
Common problems and Troubleshooting methods	28

DESCRIPTION OF COMPONENTS AND PARTS

a. Schematic diagram of components and parts

TOP VIEW

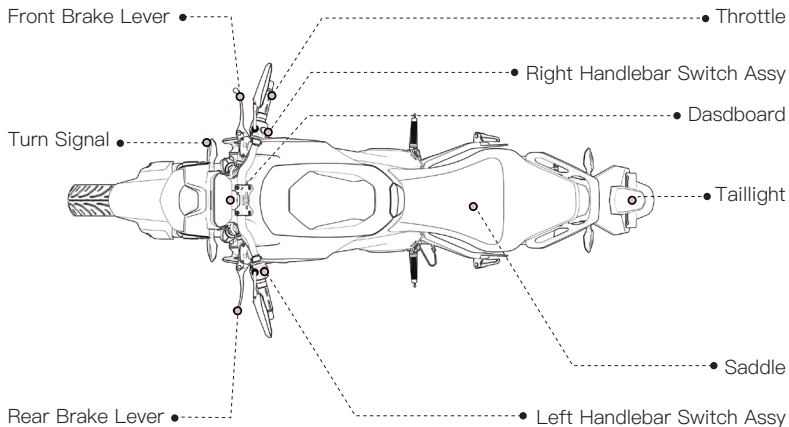

DESCRIPTION OF COMPONENTS AND PARTS

a. Schematic diagram of components and parts

SIDE VIEW

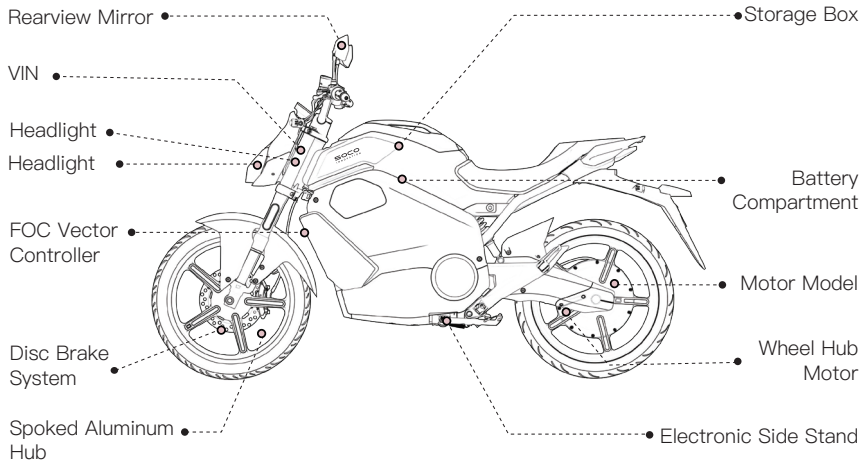

DESCRIPTION OF COMPONENTS AND PARTS

b. Warning Label

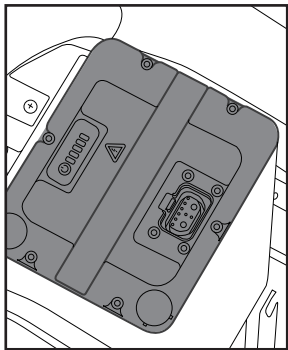

Battery

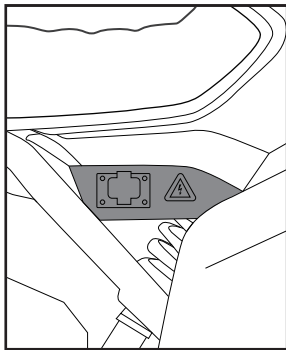

Charging Port

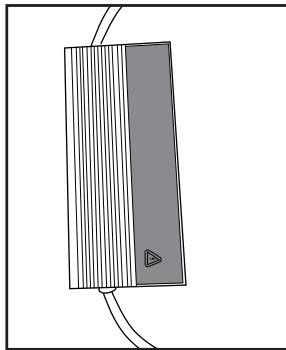

Charger

DESCRIPTION OF COMPONENTS AND PARTS

c. Dashboard Overview

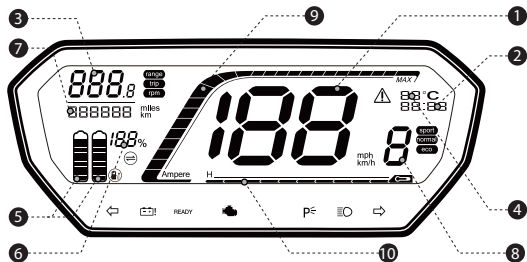

1 Speedometer

Display current speed of the vehicle.

2 Clock

Display current time.

3 Endurance Mileage/ Subtotal Mileage/ RPM

5 Power Display Bar

Display current amount of energy remaining in battery A and B.

6 State of Charge (SoC)

Display the SoC in percentage.
(*When using two batteries, the SoC shows the percentage of the higher one.)

8 Ride Mode/Forward or Reverse Mode

Display Ride Mode/Forward or Reverse Mode.

9 Controller Output Current

Display real-time Controller Output Current.

10 Controller Temperature

Display current operating temperature of the controller.



Charging



Error Indicator

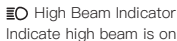

High Beam Indicator
Indicate high beam is on

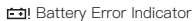

Battery Error Indicator

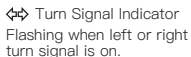

Turn Signal Indicator
Flashing when left or right turn signal is on.

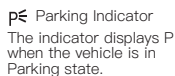

Parking Indicator
The indicator displays P when the vehicle is in Parking state.



OBD Checking Error Codes
See Page 28 TROUBLESHOOTING for reference.

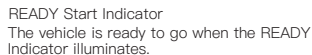

READY Start Indicator
The vehicle is ready to go when the READY Indicator illuminates.

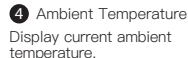

Ambient Temperature
Display current ambient temperature.



Sport Mode



Normal Mode



Eco Mode

DESCRIPTION OF COMPONENTS AND PARTS

d. Brake

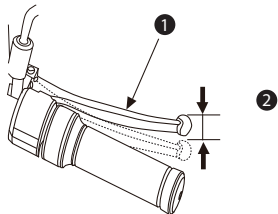

1 Front Brake Lever 2 Front Brake Lever Free Stroke

Front Brake

The brake is an important safety component of an electric vehicle and should always be properly adjusted. The distance that the end of the front brake lever moves from the start of braking to the time when the front wheel just feels the brake dragging is called the front brake free stroke.

Measure the distance that the end of the front brake lever can travel. Free stroke should be: 10–20mm

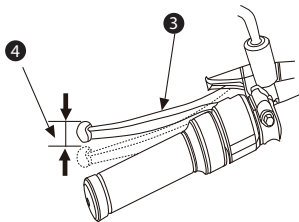

3 Rear Brake Lever 4 Rear Brake Lever Free Stroke

Rear Brake

Park the vehicle on solid level ground with the main stand. The distance the rear brake lever moves from the start of braking to when the rear wheel just feels the brake dragging is called the rear brake lever free stroke.

Rear brake lever free stroke should be: 10–20mm

OPERATION GUIDE

a. Left Combination Switch

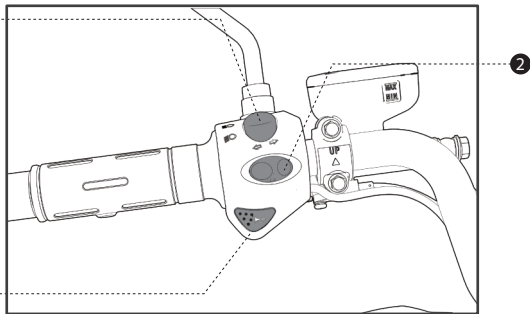
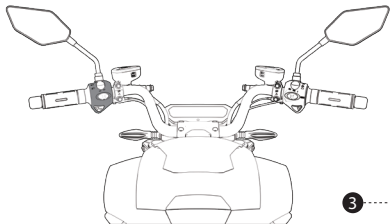

① High / Low Beam Switch

Up position, high beam on;
Down position, low beam on.

② Turn Signal Switch

Turn to left, left turn signal on;
Turn to right, right turn signal on.

③ Horn Button

Press, horn on; Release, horn off.

OPERATION GUIDE

b. Right Combination Switch

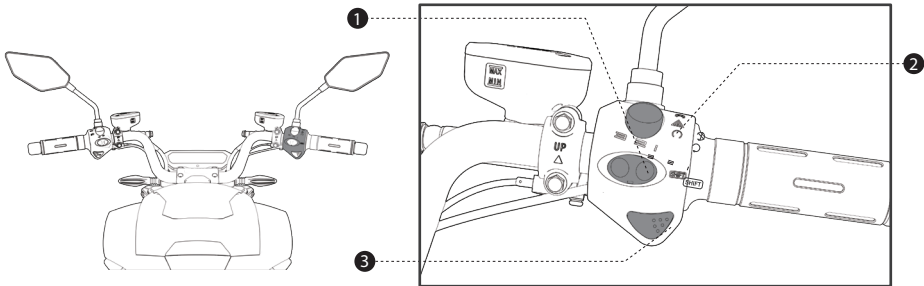

1 Mode Switch

The vehicle provides three ride modes: 1 eco, 2 normal, 3 sport .
Position Right for Mode 1;
Position Middle for Mode 2;
Position Left for Mode 3.

2 Emergency Flasher Switch

Up position, emergency flasher on;
Down position, emergency flasher off.

3 Parking Switch

When the parking switch is pressed to the up position, the vehicle enters parking state, and the parking indicator (P) illuminates;
When the parking switch is pressed to the down position, the READY indicator illuminates, and the vehicle exits parking state.

OPERATION GUIDE

c. Intelligent Remote Control Operation

TS is equipped with second generation SOCO Intelligent Remote Control, with a press of the button, you can lock or unlock the vehicle within effective distance.

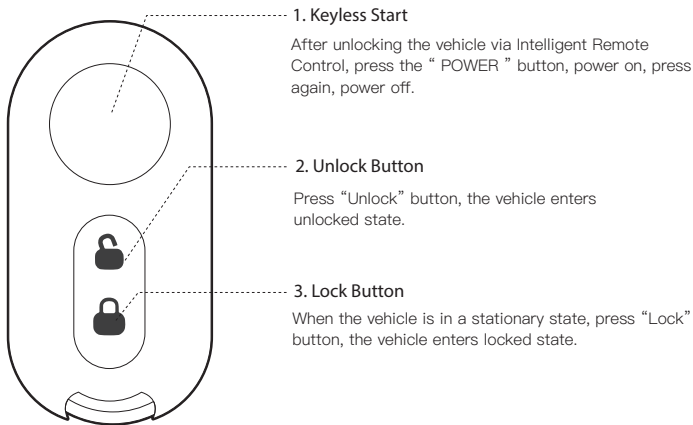

OPERATION GUIDE

d. Steering Wheel Lock Operation

- 1 After parking the vehicle, turn the handlebar all the way to the side. Insert the key and turn the key clockwise to lock the steering wheel.
- 2 Turn the key counterclockwise to unlock the steering wheel.

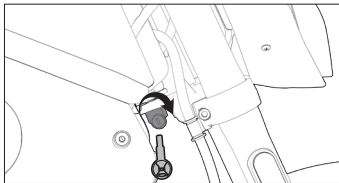
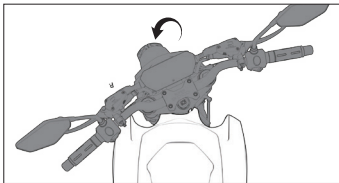

e. Open the Storage Box and Seat

- 1 Insert the key and turn the key clockwise. when you hear the click, you can open the storage box.
- 2 Insert the key and turn the key counterclockwise to open the cushion .

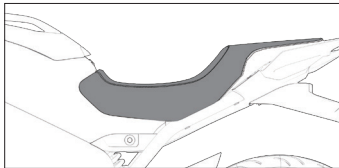
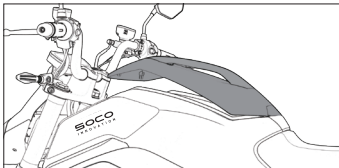

OPERATION GUIDE

f. Air Circuit-breaker

The air circuit-breaker serves as the main power protection for the entire vehicle. When the vehicle circuit is abnormal or short circuit causes the current to exceed the safety setting, the air circuit-breaker will automatically disconnect to ensure safety.

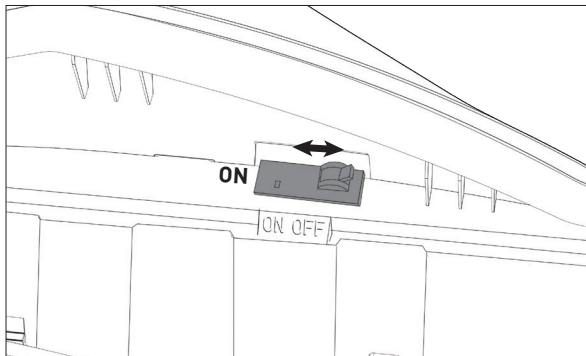

TIPS: To ensure the safety of the vehicle and the user, please turn off the air circuit-breaker when washing the vehicle, storing the vehicle for extended periods of time or taking out the battery pack

RIDING GUIDE

a. Pre-ride Checklist

Before operating your TS Smart Electric Scooter, check the following to ensure your own safety:

- 1 Check whether the handlebar is stable and flexible when turning.
- 2 Check whether the left and right handlebar controls work properly.
- 3 Check whether the throttle control works properly.
- 4 Make sure the tire pressure is within normal range. The suggested tire pressure is 175 kPa for the front tire, 200 kPa (Single Person) or 225 kPa (Two Persons) for the rear tire.
- 5 Make sure that there are no cracks, damage, wear, foreign object puncture or adhesion on the tire surface.
- 6 Check tread depth of both tires is enough. If the tire is worn to the black shaded mark on the diagram, it needs to be replaced.
- 7 Check if any error warning sign illuminates on the dash when power on.
- 8 Check whether the battery capacity is sufficient for your trip.
- 9 Check whether all lights function properly.
- 10 Check whether horn function properly.
- 11 Check whether rearview mirrors are clean and adjust them to appropriate angle.
- 12 Check whether brake fluid is sufficient, whether the handlebar and brake system function properly.

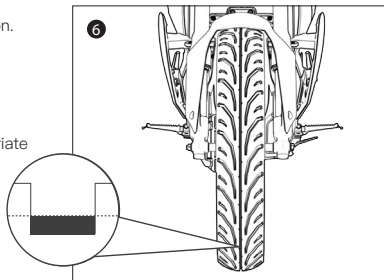

If you have any questions, please contact SOCO Customer Service.

RIDING GUIDE

b. Starting the vehicle

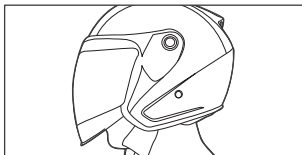

1 Put on the helmet.

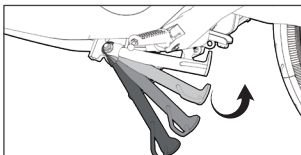

2 Get on your TS, retract the side stand and center stand.

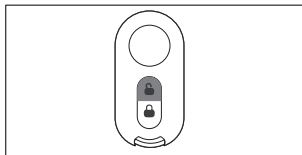

3 Press "Unlock" button on the intelligent remote control.

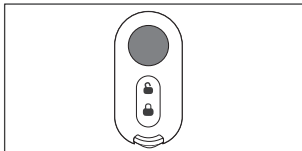

4 Press "Power" button on the intelligent remote control.

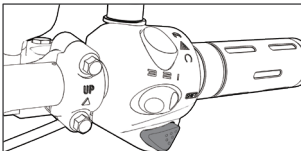

5 Press the "Parking" button, apply the brake to unpark the vehicle, parking indicator turns off.

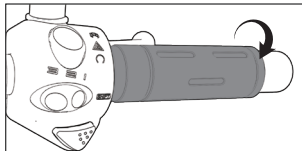

6 Gently twist the throttle to ride on the road.

Note: When the vehicle remains stationary for a long time in power-on state, it will switch to the parking state. Gently hold the brake, and the power will be on again.

RIDING GUIDE

TIPS:

- 1 Before riding, make sure the side and center stand are retracted, the handlebar is unlocked.
- 2 DON'T press "PARKING" button or kick out the kickstand while riding, as it will cut off the power suddenly, which may cause unforeseen danger.
- 3 You can only start the vehicle when it's in the stationary state. If an error occurs while riding, please slide or push the vehicle to a safe area. Do not attempt to restart the vehicle while riding or in the driving lane to avoid danger.

c. Riding Safety Tips

- 1 When the vehicle is starting, you should slowly accelerate in order to avoid excessive starting current caused by instantaneous rapid acceleration and increased energy consumption.
- 2 Under the premise of ensuring safety, try to maintain a constant speed, reduce frequent start, brake, instant acceleration, etc. to avoid increased energy consumption.
- 3 The maximum load for TS is 180KG. Overloading is strictly prohibited.
- 4 When pushing the vehicle, please press the "Parking" button or switch to Forward Mode to prevent accidents caused by sudden start of the vehicle due to unintentional turning of the throttle control.
- 5 Please cut off the power while parking, and remove the key or switch to Forward Mode.
- 6 When the vehicle remains stationary for a long time in power-on state, it will switch to the parking state. Gently hold the brake, and the power will be on again.

BATTERY USE INSTRUCTION

a. On-board Charging

- 1 Plug the charger into on-board charger socket.
- 2 Connect the charger to a power supply, and the indicator on the charger illuminates red during normal charging.
- 3 Once the vehicle is fully charged, the indicator on the charger illuminates green.

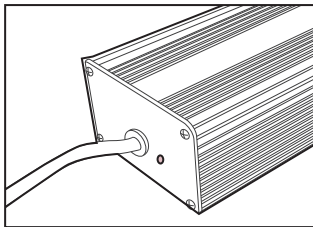
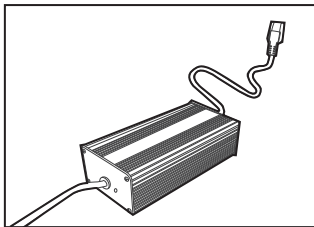

Charging:

the indicator illuminates red.

Fully charged:

the indicator illuminates green.

Error:

the indicator flashes red and green alternately

BATTERY USE INSTRUCTION

b. Off-board Charging

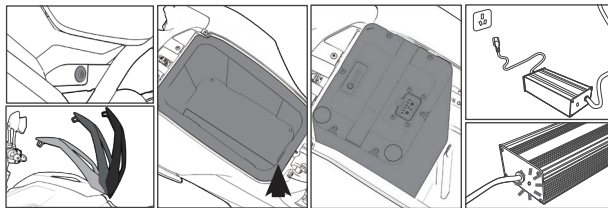

- 1 Open the battery compartment, switch off the air circuit-breaker and take out the battery compartment cover.
- 2 Disconnect the battery pack main plug.
- 3 Put the main plug of the charger into the battery charging port, and then connect the AC power plug to a power supply, the indicator illuminates red while the battery pack is being charged.

TIPS:

Pay attention to water damage, and prevent the battery pack from being exposed or submerged to water

- Charging temperatures: 0 – 40°C, discharging temperature: –15 – 45 °C.
- Charge the battery pack after using, if you plan on not riding the vehicle for a long time, please take the battery pack out of the vehicle.
- Forbidden to short-circuit the battery pack.
- Please prevent children from touching the battery pack and forbidden to throw it into the fire.
- Forbidden to impact or press strongly on the battery pack.
- Only charge the battery pack with the designated special charger. Do not use unapproved chargers to charge the battery pack.
- The battery pack and charger have been strictly inspected before leaving the factory, forbidden to disassemble the battery pack without authorization.
- Do not park the vehicle indoors or in the hallway. Do not charge the vehicle indoors or in the hallway. The battery/vehicle should be kept away from combustible materials when charging.

BATTERY USE INSTRUCTION

c. Storage, Maintenance and Transportation

- 1 In case you plan on storing your battery pack for a long period of time, please disconnect the battery from the vehicle to prevent it from over-discharging. Keep the battery in a dry, ventilated place and fully charge it with the charger once every two months.
- 2 The battery pack and charger should be stored in a clean, dry and well-ventilated place and avoid contact with corrosive substances, and be kept away from power, fire and heat sources.
- 3 Battery pack storage conditions: ambient temperature 0–25°C, ambient humidity ≤65%RH
- 4 To avoid electric shock, please cover the rubber plug of the vacant battery plug when using single battery pack.

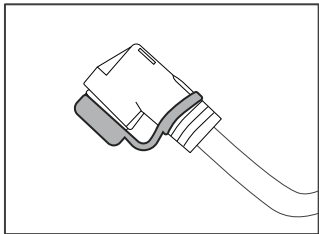

If you encounter any problems, please contact the after-sales service department of SUPER SOCO.

APP INSTRUCTIONS

TS Smart Electric Motorcycle supports wireless communication, **GPS**, etc., which can connect the vehicle with your smart phone.

You can manage and check your vehicle using your smart phone through the **SOCO App**.

*Please note that some functions require wireless network and location function

Available on **iOS** and **Android** platforms, please check your smart phone operating system before installation.



iOS platform: **App** requires **iOS 9.0** or later.



Android platform: **App** requires **Android 4.4** or later.

APP main features:



On-Board Diagnostics:

When the vehicle is ready to start, you can access the condition of the vehicle by performing a one-button examination.



Anti-theft System:

The vehicle will sound the alarm when an unauthorized movement of the vehicle occurs. The app will notify the owner and start tracking the position of the vehicle.



Data Record:

Users can access the vehicle information, battery level, distance travelled, tracking and other information through the APP.



Social Networking:

Users can make friends and build the community through the app and enjoy the fun of riding online and offline.

The functions of SOCO APP may vary with version update, function upgrade and different vehicle types. Please refer to the actual content of the latest version.

MAINTENANCE

Regular maintenance can improve the service life and driving safety of TS Smart Electric Motorcycle. It is suggested that you take care of the vehicle following the advices below:

a. General cleaning and maintenance

***Cleaning:** Please use clear water and mild detergent to clean the vehicle, and use soft cloths and sponges to clean the surface. Please do not use metal brushes, sandpapers etc. to prevent the parts surface from scratching. After cleaning, dry it with a soft cloth.

***Storage:** Please move the vehicle to a dry and cool indoor place, reduce exposure to sun and rain to avoid rust and corrosion of parts, thereby prolonging the service life of your vehicle.

b. Warnings

- 1 Please turn off the air switch before cleaning.
- 2 Please do not use high-pressure washers to flush the vehicle directly, so as to avoid internal electrical parts and lines being exposed to water intrusion and soaking, which may cause vehicle mechanical failure or other potential accidents.
- 3 Before long-term storage, please turn off the air switch to cut the power supply and avoid over discharging and please charge the battery once a month.
- 4 After long-term storage, please fully charge your vehicle before operating.

COMMON PROBLEMS AND TROUBLESHOOTING METHODS

a. FAQ and Troubleshooting

Errors	Causes	Solutions
No power, “start” won’t light up.	<ol style="list-style-type: none">1. Battery is poorly connected2. Air circuit breaker is not turned on	<ol style="list-style-type: none">1. Please check if the main battery plug is properly connected2. Turn on the Air circuit breaker
Twist the throttle, the motor won’t start.	<ol style="list-style-type: none">1. Low battery2. Kickstand is not retracted3. Parking button is not switched off4. Throttle fault5. Controller connector is loose6. Controller fault7. Motor fault	<ol style="list-style-type: none">1. Charge the battery2. Retract the kickstand3. Press the parking button to unpark4. Replace the throttle5. Replug the controller connector6. Replace the controller7. Replace the motor
Speed is slow or mileage is short.	<ol style="list-style-type: none">1. Low battery2. Flat tire3. Overloading4. Poor braking5. Battery aging or reaching end of life	<ol style="list-style-type: none">1. Charge the battery2. Please inflate the tires to normal pressure before riding3. Observe load limits4. Replace brake pads and check the brake system before riding5. Replace the battery
Battery won’t charge	<ol style="list-style-type: none">1 The charging plug is poorly connected.2 Did not use the correct charger3 Battery aging or reaching end of life	<ol style="list-style-type: none">1 Please check if the main plug is properly connected2 Please use SOCO designated charger3 Replace the battery

COMMON PROBLEMS AND TROUBLESHOOTING METHODS

b. Error Codes

Errors	Causes	Solution
Error 99 on Dash	Controller communication fault	Please contact customer service or dealer
Error 98 on Dash	Controller stops working (possibly overcurrent, locked-rotor, under voltage, overtemperature)	Please stop for a while and then start again
Error 97 on Dash	Controller power transistor fault	Please contact customer service or dealer
Error 96 on Dash	Controller Hall sensor fault	Please contact customer service or dealer
Error 95 on Dash	Controller throttle fault	Please check the throttle wiring or contact customer service or dealer
Error 94 on Dash	Battery communication fault	Please check the charging port connection, or contact customer service or dealer
Error 93 on Dash	Charging overcurrent	Please stop charging, and check the charger
Error 92 on Dash	Charging overvoltage	Please stop charging, and check the charger
Error 91 on Dash	Battery at high temperature	Please stop charging/riding wait until the battery temperature drops before attempting to ride
Error 90 on Dash	Discharging overcurrent	If it keeps showing Error 90, please stop riding and wait for a moment
Error 89 on Dash	Low temperature charging	Please take out the battery and charge it in a warm indoor place
Error 88 on Dash	Low temperature discharging	Please take the vehicle or battery to a warm indoor place, and wait for a moment
Error 87 on Dash	Internet connection fault	Please move the vehicle to an open area, or contact customer service or dealer
Error 86 on Dash	GPS connection fault	Please move the vehicle to an open area, or contact customer service or dealer

COMMON PROBLEMS AND TROUBLESHOOTING METHODS

c. Battery Troubleshooting

Status	Errors	Causes	Solutions
Before using	The battery has no power, no response when starting the vehicle	Low battery	Charge the battery.
In use	When riding with low power, power off occurs when battery level drops below 10%	Low battery, low voltage protection, normal phenomenon	Charge the battery.
In use	Error 88 on Dash	Low temperature discharging	Please move the vehicle to a warm indoor place, and wait for a moment
In use	Error 90 on Dash	Discharging overcurrent	If it keeps showing Error 90, please stop riding and wait for a moment
In use	Error 91 on Dash	High discharge temperature	Please stop riding, switch off the air circuit-breaker and wait for a moment
In use	Error 94 on Dash	Battery communication fault	Please check the charging port connection or contact customer service or dealer
In use	Overnight or next day, the dash shows a drop in power	ECU, controller, alarm electrical components will drain the battery. Normal phenomenon	Operate as normal

COMMON PROBLEMS AND TROUBLESHOOTING METHODS

Status	Errors	Causes	Solutions
In use	The mileage is different from official data	Official Mileage is the one in a special environment and condition, and is related to road conditions, weather, temperature, wind resistance, load capacity and other factors	If you have any questions, please contact customer service or dealer
Storage	Start the vehicle, "Power" not on	Battery has been stored for too long, power is used up	Charge the battery. If it can't be charged, please contact customer service or dealer
Charging	Error 89 on Dash	Low temperature charging	Take out the battery and charge it in a warm indoor place
Charging	Error 92 on Dash	Charging overvoltage	Please stop charging, and check the charger
Charging	The charger heats up during charging	Charging process of the charger internal current is high and will generate a lot of heat, the metal housing can effectively dissipate heat, which will lead to a higher temperature of the housing	Operate as normal, and use the charger in a dry, ventilated place
Battery flooded water	The battery does not work properly and the vehicle cannot be started	The vehicle is rained on, soaked in water, waded too deep in water, causing battery flooded water	Stop using. Please contact customer service or dealer
Battery shell broken	The battery has been impacted or dropped, causing the shell to break or crack	Battery shell damage caused by the use of the vehicle	Stop using. Please contact customer service or dealer



SOCO Smart Electric scooter

Download App



Android



iOS

Bind your vehicle



Available on **iOS** and **Android** platforms, please check your smart phone operating system before installation.

iOS platform: **App** requires **iOS 9.0** or later.

Android platform: **App** requires **Android 4.4** or later.

CHECK LIST

RANGE	1000 KM	2500 KM	5000 KM	7500 KM	10000 KM	12500 KM	15000 KM	17500 KM	20000 KM	Torque
Brake fluid	<input type="radio"/>		<input type="radio"/>				<input type="radio"/>			
Tire pressure and wear	<input type="radio"/>	<input type="radio"/>	<input type="radio"/>	<input type="radio"/>		<input type="radio"/>	<input type="radio"/>	<input type="radio"/>		
Front and rear brake shoes wear		<input type="radio"/>	<input type="radio"/>	<input type="radio"/>		<input type="radio"/>	<input type="radio"/>	<input type="radio"/>		
Front and rear brake discs wear			<input type="radio"/>				<input type="radio"/>			
Front axle nut fastening	<input type="radio"/>		<input type="radio"/>				<input type="radio"/>			59N.m
Rear flat fork nut fastening	<input type="radio"/>		<input type="radio"/>				<input type="radio"/>			59N.m
Motor nut and retainer bolt fastening	<input type="radio"/>		<input type="radio"/>				<input type="radio"/>			80N.m
Front and rear shock bolt fastening	<input type="radio"/>		<input type="radio"/>		<input checked="" type="radio"/>		<input type="radio"/>		<input checked="" type="radio"/>	F.Upper 22N.m/F.Lower 32N.m/ R.45N.m
Steering column locking nut										74N.m
Front disc brake bracket fastening (with threadlocker)	<input type="radio"/>		<input type="radio"/>				<input type="radio"/>			26N.m
Front brake disc fastening (with threadlocker)	<input type="radio"/>		<input type="radio"/>				<input type="radio"/>			42N.m
Rear disc brake bracket fastening (with threadlocker)	<input type="radio"/>		<input type="radio"/>				<input type="radio"/>			26N.m
Rear brake disc fastening (with threadlocker)	<input type="radio"/>		<input type="radio"/>				<input type="radio"/>			42N.m
Battery	<input type="radio"/>	<input type="radio"/>	<input type="radio"/>	<input type="radio"/>		<input type="radio"/>	<input type="radio"/>	<input type="radio"/>		

Note: Check the lithium battery balance by BMS reading and manual measurement.

MAINTENANCE RECORD:

Content:

Date:

MAINTENANCE RECORD:

Content:

Date:

MAINTENANCE RECORD:

Content:

Date:

MAINTENANCE RECORD:

Content:

Date:

MAINTENANCE RECORD:

Content:

Date:

MAINTENANCE RECORD:

Content:

Date:

Manufacturer: Yanaka (Xuzhou) New Energy Locomotive Co., Ltd.

Address: Accessories Park, Hi-tech Industrial Development Zone, Changdian Town, Fengxian County,
Xuzhou City, Jiangsu Province, China

Assembly plant: Changzhou Kwang Yang Motor Co., Ltd.

Address: No.10 Lvtang Road, New North District, Changzhou City, Jiangsu Province, China

The illustrations in this manual may differ from the actual products.

We reserve the rights to modify drawings and products to improve quality and performance without prior notice.